



Operating Instruction

Gearbox lift



Type

Serial number

Date

Operating Instruction

Table of Contents

Table of Contents

1	Safety	2
1.1	Safety instructions in this manual	2
2	Introduction	3
2.1	Application range of BLITZ PIT LIFTS	3
2.2	Warranty and Liability	3
3	Safety / Accident Prevention	4
3.1	Remarks concerning observation of instructions for use	4
3.2	Obligations of the operator.....	4
3.3	Dangers when operating the pit lift	4
3.4	Organizing requirements.....	4
3.5	Maintenance works, remedy of faults and disposal	5
3.6	Special Dangers	5
4	Technical data	6
5	Transport	6
6	Initial Operation	6
6.1	Prior to starting operation	6
7	Handling and Operation	7
7.1	Load lifting	7
7.2	Lowering of load.....	7
7.3	Load Carrying Devices	8
8	Troubles/Reasons/Remedies	9
9	Maintenance and repair	10
9.1	Maintenance works	10
9.2	Time-fixed works	10
10	EC Declaration of Conformity	12

1 Safety

1.1 Safety instructions in this manual



Danger
Risk to life and limb.



Warning
Material damage.



Information and tips.

2 Introduction

BLITZ lifts represent the result of an experience lasting for years. The high demand for quality as well as the superior concept guarantee reliability, high durability and economic operation. To avoid needless damage or danger, you should read carefully and observe these operating instructions.

2.1 Application range of BLITZ PIT LIFTS

BLITZ Pit Lifts are only to be used for partial lifting of vehicles with follow up support and/or lifting or lowering of vehicle parts (as e.g. engines, gear-boxes etc.). The total load must not exceed the allowable capacity of the pit lift.



Any other use above the described function is not allowed.

Messrs. BlitzRotary GmbH will not take any responsibility for damages resulting from misuse. The risk is entirely on the part of the user.

The appropriate operation also covers:

- observation of all items of these instructions for use and
- the carrying out of Inspection- and Serviceworks and the specified tests.

2.2 Warranty and Liability

Generally our "General Conditions of Sales and supplies" are valid. These are available to the user as of the time of contracting. Warranty- and Liability- claims for personal and property damage are excluded if based on one or more of the following reasons:

- use of the lift contrary to its destined application.
- inexpert mounting, set to operate, running and maintaining the pit lift.
- Operation with condensate- and/or dirt-holding compressed air.
- Operating of the pit lift with defect safety devices or inexpertly mounted or not functional safety and protection devices.
- Neglecting the remarks in the instructions for use concerning transport, storage, mounting, starting, operating and maintaining of the pit lift.
- Unauthorised changing of the pit lift.
- Insufficient control of parts, which are liable to wear.
- Inexpertly carried out repairs.
- Cases of catastrophe by foreign matters and Act of God.

Service-requests and cost for returning, caused by non-observation of the listed points, cannot be accepted by us. Therefore in case of return please approach the manufacturer.

3 Safety / Accident Prevention

The pit lift must only be operated by trained personal. Unauthorised people are not allowed to operate the pit lift!

3.1 Remarks concerning observation of instructions for use

- Prior condition for safety-conform and faultless operation of the pit lift is the knowledge of the general safety remarks and safety instructions.
- The instruction for use have to be observed by all persons working with the pit lift. Especially the chapter „Safety/Accident Prevention“ has to be observed.
- In addition to the safety remarks of the instructions for use the regulations and instructions being valid at the place of operation have to be considered.

3.2 Obligations of the operator

The operator is obliged to allow only those persons complying to the following requirements to work at the unit

- being well acquainted with the basic regulations concerning labour safety and accident prevention and being trained to operate the unit
- having read and understood the chapter concerning safety and warning instructions and confirmed that by their signature.

3.3 Dangers when operating the pit lift

BLITZ Pit Lifts are designed and built according to technical standard and the approved regulations for technical security. Yet, danger for body and life of the operator may turn up when using the pit lift inexpertly.

The unit must only be operated

- for its appropriate use
- in unobjectionable condition concerning technical security



Warning

Disturbances prejudicing the safety have to be removed immediately.

- The pit lift must only be operated when there is no danger for persons.
- The motion area of the pit lift must be held free.
- No persons should be allowed within the motion area of the pit lift.
- The allowable capacity of the pit lift must not be exceeded.
- Entering of the pit lift, ascending with it and mounting of the load is forbidden.
- The lift must only be loaded centrally, lift the vehicle, look for safe harbouring of it and only then can the vehicle be lifted to the desired height. Secure vehicle against rolling off.
- Lifting and lowering movements must be carried out evenly. While in motion observe the load.
- Lifted load must be secured by supporting bridges or tripods.

3.4 Organizing requirements

- The instructions for use are constantly to be kept at the place of operation being at hand at any time.
- In addition to the instructions for use rules pertaining to other regulations i. e. accident prevention and environmental rules are to be observed and directed.
- Safety- and danger alert operation of personal is occasionally and by observing the instructions for use to be controlled.
- As far as required and ordered by regulations personal protective equipment is to be used.
- All safety- and danger-hints at the pit lift are to be observed.
- Keep all safety- and danger-hints at the pit lifts in readable condition.
- Changes, additional mountings or constructional variations impairing the safety must not be carried out without the approval of the manufacturers. This goes particularly as far as welding works at carrying parts are concerned.

- Spare parts must comply with technical requirements laid down by the manufacturer. This is only warranted with original parts.
- Consider time intervals given or fixed in instructions for use for repeated tests/ inspections.
- In case of malfunction stop and secure the pit lift immediately.
- Care for remedy of faults immediately.

3.5 Maintenance works, remedy of faults and disposal

- Fixed Adjusting-, maintenance- and inspection-works and time intervals including details for exchange of parts/ part components as mentioned in the instructions for use are to be adhered to. These works must only be carried out by expert personal.
- After maintenance- and repair works loose screw connections must always be firmly tightened.
- Care for safe and friendly to environment disposal of operating and auxiliary process materials as well as exchanged parts.

3.6 Special Dangers

Hydraulic, Pneumatic

- Works at hydraulic devices must only be made by personal with special knowledge and experience in hydraulic!
- All tubes, hoses and connections must in regular intervals be checked for leaks and visible damages. Damages must be repaired immediately. Splashing oil may lead to injuries and fire!
- Pressure lines to be opened (hydraulic, pneumatic) must be set pressureless prior to starting repair works.
- Hydraulic- and pneumatic lines are to be laid out and mounted in an expert way. Do not interchange connections. Armatures, lengths and quality of tubings must comply with the requirements.

Oil, grease and other chemical stuff

While handling oils, greases and other chemical stuff the existing safety rules as they are valid for the single products are to be observed.

Complying Safety Standards

DIN EN 292/DIN EN 294/prEN 349/EN 414/
EN 418/prEN 811/EN 50099/EN 60204
ISO 1219/ISO/DIS 11530

4 Technical data

Model		Master Jack 2,5	Master Jack 4	Junior Jack 0,5	Junior Jack 2
Capacity	t	2,5	4	0,5	2
Lifting height	mm	1100	1100	1130	1080
Working pressure hydraulic	bar	125	200	126	32
Working pressure pneumatic	bar	13	13	-	6
Oil capacity Tank 1	l	5,0	5,0	2,9	2,9
Oil capacity Tank 2	l	1,2	1,2	-	-
Weight	kg	195	195	60	61
max. lowering speed at nominated load	mm/s	150	150	150	150

Tab. 1:

5 Transport

During transport it is to be observed that in the horizontal position of the Lift the control instruments are to show upwards, as otherwise oil may be lost. (see also red label at pit lift)

6 Initial Operation

6.1 Prior to starting operation

- Compressed air supply must only be done via a service unit with water separator, oiler and pressure reducer installed directly in the pit. The unit has to be set to 6 bar. For the oiler must be used only non resinous hydraulic oil like HLP22.
- Check oil level
- De-air hydraulic

Operating Instruction

Handling and Operation

7 Handling and Operation



Warning

When operating the pit lift you will have to observe all instructions from section „safety“ and the instructions for the valid accident prevention regulations.

- The pit lift must only be operated by specially trained personal.
- Pit lifts should only be put into movement when no persons are endangered.
- The movement range of the pit lift must be kept free and no persons should stay in the moving region.
- The maximal allowable capacity of the pit lift must not be exceeded.
- Standing on the pit lift, being lifted by it and mounting of load is not allowed.
- The lift must only be loaded centrally, lift the vehicle, look for safe harbouring of it and only then can the vehicle be lifted to the desired height.
- Use the lift only on a solid base able to carry the weight.
- Lifting and lowering movements must be carried out evenly. While in motion observe the load.
- Lifted load must be secured by supporting bridges or tripods.

7.1 Load lifting

For load lifting the car wheel should be able to afterturn. (open break and put gear into neutral)

- Button “Quick Lift“ (1) to be pressed until carrying plate has reached the load carrying point (Junior Jack pedal (Fig. 2: 1a)
- Load carrying device to be lead to even points meant for load lifting by car manufacturers.
- Ensure safe harbouring of vehicle.
- Button “Pneumatic Motor“ (2) to be pressed until the load has reached the desired height.
- Secure vehicle against rolling off (drag shoe) and use supporting bridge.



For exact adjustment of desired height and in case of insufficient air supply pumping can be done by the foot hydraulic pump (3).

7.2 Lowering of load



Warning

Lowering motion to be carried out slowly and evenly. Observe the load during Motion.

- Remove roll-off-security measure (drag shoe)
- Lift vehicle slightly and remove supporting bridges.
- For lowering the load move lever (4) to the front and turn slowly to the right.



The lowering speed will be regulated steplessly by the turning movement.

- Return lever (4) into rest position.

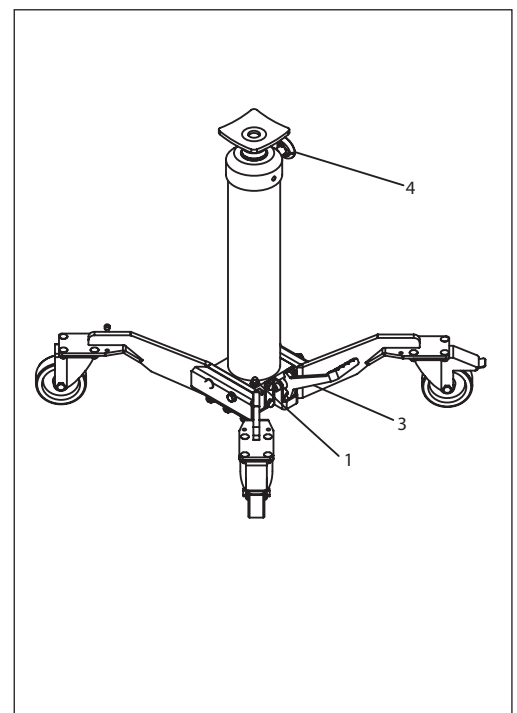

Fig. 1:

Operating Instruction Handling and Operation

7.3 Load Carrying Devices

For safe lifting of vehicles and vehicle parts by means of the pit lift various load carrying devices are available, such as carrying plates, axle traverses, gear-box plates, special pick-up devices and extension pieces.

Supporting Bridges

Lifted vehicles have to be secured by means of supporting bridges or trestles. Supporting bridges are always manufactured according to pit measurements. Their safe support must be granted over the whole length of pit.



Informations for use

- The allowable capacity of the load carrying device must not be exceeded.
- Irrespective of the load carrying device the load-centre-point always has to be exactly over the pit lift.
- Use only load carrying devices with correct diameter of pin.
- Do not stack extension pieces.
- Vehicle parts must only be transported on the pit lift if it is completely lowered and if parts are secured with tapes or chains prior to being moved.

For further information concerning the complete program for load carrying and load supporting devices please approach the manufacturers

BlitzRotary GmbH
Hüfinger Straße 55
D-78199 Bräunlingen
Telefon +49.771.9233.0
Telefax +49.771.9233.99
info@blitz.rotarylif.com
<http://blitz.rotarylif.com>



Operating Instruction Troubles/Reasons/Remedies

8 Troubles/Reasons/Remedies

Piston rod does not move up completely.

Reason	Remedy
Insufficient oil in tank.	<ul style="list-style-type: none">• Refill oil up to recommended quantity. (see oil change in section "Maintenance and repair")

Piston rod does not move up or descends under load.

Reason	Remedy
Ball valves untight or lip ring damaged.	<ul style="list-style-type: none">• Ask for service people!

Pit lift loses oil at the control.

Reason	Remedy
Condensate in hydraulic oil.	<ul style="list-style-type: none">• Check oil level, if required drain condensate (see section "Maintenance and repair")
Piston gasket untight	<ul style="list-style-type: none">• Ask for service people !

Loosing oil at the piston.

Reason	Remedy
Piston damaged and consequently seal damaged.	<ul style="list-style-type: none">• Ask for service people.

9 Maintenance and repair



Warning

- Maintenance and repair works must only be carried out by specialists at unloaded, pressure-less lift.
 - After finishing maintenance and repairs loose screw connections are to be tightened properly.
 - Care for safe and environment-friendly disposal of operating and auxiliary process materials (hydraulic oil) as well as exchanged parts.
 - The lifting devices are to be kept in proper condition and prior to its use are to be checked for safety to the personal and the vehicles.
 - Prior to all maintenance and repair works disconnect the pit lift from the air supply!
 - After having finished work at the hydraulic system it must by all means be de-aired.
 - After all Maintenance and repair works test the pit lift and enter the result into the examination book.
-

9.1 Maintenance works

General

- The ram and the pin of the load carrying device must be kept free from sand and dirt.
- While working with adhesive under bottom agents or with lacquer the ram must be protected.
- The pit lift should not be cleaned with high pressure or steam cleaners.
- For cleaning the pit lift no aggressive cleaning agents should be used.

9.2 Time-fixed works

Weekly

- Service-unit of compressed air-line to be checked and serviced.
- The pin of load carrying devices as well as the hole of the pit lift should be cleaned and sprayed with a rust protecting oil.

Quarterly

- Check oil level

Yearly

- Oil-change

Description of Maintenance works

De-Airing of hydraulic system

- Footpump (3) to be operated 5 to 10 times with simultane operation of the lowering valve (4).

Oil level control

Prior to oil level control

- Disconnect the pit lift from the pressure line.
- Oil level 1 (Container for load stroke) lifting ram to be descended completely. Remove oil bar (2) by unscrewing and check oil level.

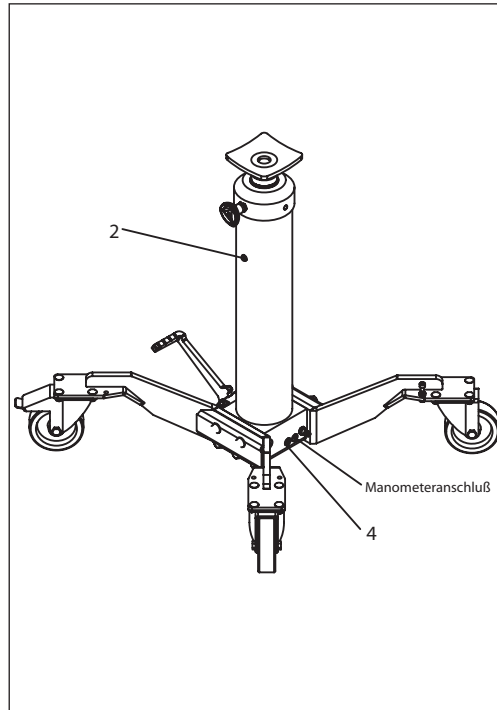

Fig. 2:

Oil change

For oil change you will require:

- Oil tray
- Hydraulic oil, class HLP, viscosity ISO-VG 10, 22 or 32. (e.g., HLP 10). Quantity of oil see technical data.

Before changing oil

- disconnect pit lift from air supply



Warning

Drain oil into a suitable container and care for proper disposal.

Oil container

- descend ram completely.
- oil drain screw (Fig. 2, Pos. 4) to be taken out and oil to be drained.
- oil drain screw (Fig. 2, Pos. 4) with seal ring to be inserted and fixed tightly.
- Oil bar (Fig. 2, Pos. 2) to be turned out.
- refill oil up to recommended level.
- Oil bar (Fig. 2, Pos. 2) with seal ring to be turned in and fixed tightly.

Operating Instruction

EC Declaration of Conformity

10 EC Declaration of Conformity

In the meaning of the EEC Machinery Directive 98/37 EC, Annex II A for installed machines.

This certification applies to the Blitz product gearbox lift (Type and Serial No. see at front cover)

The gearbox lift was constructed and manufactured in compliance with the regulations of the EC Guidelines.

BlitzRotary GmbH
Hüfingerring Straße 55
D-78199 Bräunlingen

The following harmonised standards were applied:

- 37/23 EWG
- 89/336 EWG
- EN 1493
- EN 60204.1

A complete technical documentation is available. The operating instructions that belong to the gearbox lift are on file.

Bräunlingen, 24.07.2003



F. Scherer, Management



BlitzRotary GmbH

Hüfinger Straße 55
D-78199 Bräunlingen
Telefon +49.771.9233.0
Telefax +49.771.9233.99
info@blitz.rotarylif.com
http://blitz.rotarylif.com

