

Cargolift 2.50 Saav 145 Jumbo

Operative range:

Repair and maintenance

Application:

The swivel arm lift autop Cargolift 2.50 Jumbo is suitable for any kind of repair and maintenance at light goods vehicles or little lorries if free access is required.

Of course this lift can also be used for private cars or off-roaders to compensate free capacities within your workshop.

A wide range of lifting pads allows a safe lifting of the different vehicles.

All-round swivel arm lift suitable from light goods vehicles to little city lorries.

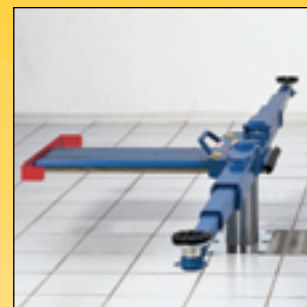

autop Maschinenbau GmbH • Sandkampstraße 90 • D-48432 Rheine
Tel. ++49 59 71/86 02-02 • Fax ++49 59 71/86 02-25 • E-Mail: mail@autop.de • www.autop.de

...a company of the STENHØJ group



Cargolift 2.50 Saav 145 Jumbo

Technical data:

Lifting capacity:	5000 kg
Piston distance:	1485 mm
Stroke length:	1800 mm
Lifting/ lowering time:	app. 45 sec
Cylinder diameter:	2 x 123 mm
Foundation depth:	2400 mm
Voltage:	230 / 400 V / 50 Hz
	16 A
Pump unit:	3.0 kW

Components:

- Two inversed hydraulic cylinders made of micro-alloyed high grade steel with hard-chrome plated surface; cylinder running on teflon sliding rings
- Bearing guide elements made of high quality special alloy, wear resisting
- Lifting height limited by end switch
- Flexible traverse cross arm, effective as synchronising/safety device as well as torsional lock
- Pump unit integrated in the cassette
- Push button control for lifting/lowering with lockable main switch and alarm signal instead of feet protectors
- Installation in a waterproof cassette. On request: dipped galvanized and/or self-carrying
- Two on-floor swivel arm bridges, easy to adjust:
 - sliding part on a traverse
 - double telescopic swivel arms
 - height adjustable lifting pads
 - integrated automatic arm locking system
 - with alarm signal instead of feet protectors

Standard paint:

(alternatively)

RAL 5019 blue

RAL 7016 grey anthracite

Special paint:

On request

And also...

we are specialised in delivery and fitting of centre-ram and twin-ram inground lifts for:

- check-in
- repair and inspection
- body repair
- maintenance

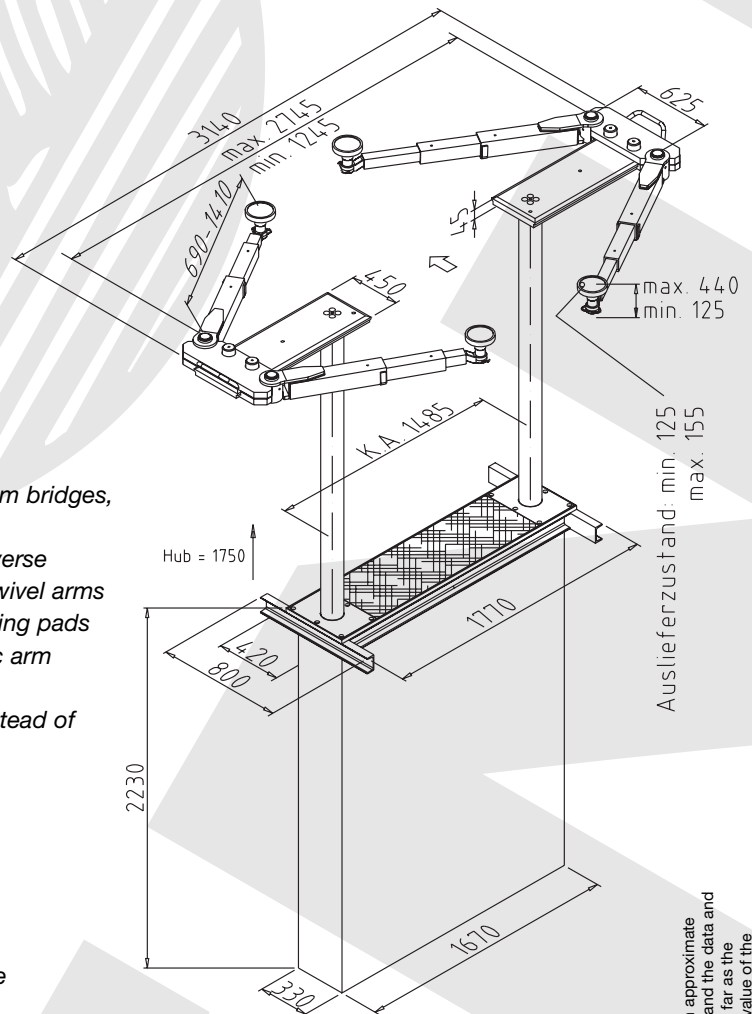

autop Maschinenbau GmbH

Sandkampstraße 90 • D-48432 Rheine

Tel. ++49 59 71/86 02-02 • Fax ++49 59 71/86 02-25

E-Mail: mail@autop.de • www.autop.de

No liability accepted for specifications that are subject to alteration - validity 06/04
The data and pictures in this product information are not binding and are only giving an approximate description. Moreover we reserve the right of differences between the goods delivered and the data and pictures given here (i.e. technical data, equipment, material and optical appearance) so far as the differences are reasonable for the customer and a possible reduction in value or utility value of the goods delivered is not considerable.