



World Leader in Lift Productivity

M50 Scissor Lifts



OPERATION & MAINTENANCE MANUAL

DECLARATION OF WARRANTY AND LIMITATION OF LIABILITY

The manufacturer has paid proper attention to the preparation of this manual. However, nothing contained herein modifies or alters, in any way, the terms and conditions of manufacturer agreement by which this lift was acquired, nor increase, in any way, manufacturer's liability to the customer.

TO THE READER





Every effort has been made to ensure that the information contained in this manual is correct, complete and up-to date. The manufacturer is not liable for any mistakes made when drawing up this manual and reserves the right to make any changes due the development of the product, at any time.

**BlitzRotary GmbH
Hüfinger Straße 55
78199 Bräunlingen**

Germany

PRINTING CHARACTERS AND SYMBOLS

Throughout this manual, the following symbols and printing characters are used to facilitate reading:

	Indicates the operations which need proper care
	Indicates prohibition
	Indicates a possibility of danger for the operators
	Indicates the direction of access for motor vehicles on to the lift
Bold Type	Important information
	WARNING: before operating this lift and carrying out any adjustment. read chapter 7 “installation” where the correct installation procedures for the lift are shown.

CONTENTS

1	GENERAL INFORMATION	4
2	PRODUCT IDENTIFICATION	6
3	PACKING, TRANSPORT AND STORAGE	7
4	PRODUCT DESCRIPTION	10
5	TECHNICAL SPECIFICATION	15
6	SAFETY	43
7	INSTALLATION	46
8	OPERATION AND USE	61
9	MAINTENANCE	67
10	TROUBLESHOOTING	69
11	EC DECLARATION OF CONFORMITY	71

1 CHAPTER 1 – GENERAL INFORMATION

This chapter contains warning instructions to operate the lift properly and prevent injury to operators or objects.

This manual has been written to be used by shop technicians in charge of the lift (OPERATORS) and routine maintenance technicians (MAINTENANCE OPERATORS).

The operating instructions are considered to be an integral part of the machine they and must remain with the lift at all times. Read every section of this manual carefully before unpacking and operating the lift. the manual gives helpful information about::

- SAFETY OF PEOPLE

- SAFETY OF THE LIFT

- SAFETY OF LIFTED VEHICLES

The company is not liable for possible problems, damage, accidents, etc. resulting from failure to follow the instructions contained in this manual.

Only skilled technicians of AUTHORISED DEALERS or SERVICE CENTRES AUTHORISED by the manufacturer shall be allowed to carry out lifting, transport, assembling, installation, adjustment, calibration, settings, extraordinary maintenance, repairs, overhauling and dismantling of the lift.

THE MANUFACTURER IS NOT RESPONSIBLE FOR POSSIBLE DAMAGE TO PEOPLE, VEHICLES OR OBJECTS IF SAID OPERATIONS ARE CARRIED OUT BY UNAUTHORISED PERSONNEL OR THE LIFT IS IMPROPERLY USED.

Any use of the machine made by operators who are not familiar with the instructions and procedures contained herein shall be forbidden.

1.1 MANUAL KEEPING

For proper use of this manual, the following is recommended:

- keep the manual near the lift, in an easily accessible place
- keep the manual in an area protected from the damp
- use this manual properly without damaging it
- do not make changes to the manual; any changes and updating can be made only by the manufacturer.

This manual is an integral part of the lift: it shall be given to the new owner if and when the lift is resold.

1.2 OBLIGATION IN CASE OF MALFUNCTION

	In case of machine malfunction, follow the instructions contained in the following chapters.
---	---

1.3 CAUTIONS FOR THE SAFETY OF THE OPERATOR

Operators must not be under the influence of sedatives, drugs or alcohol when operating the machine.



Before operating the lift, operators must be familiar with the position and function of all controls, as well as with the machine features shown in the chapter “Operation and use”.

1.4 WARNINGS



Unauthorized changes and/or modifications to the machine relieve the manufacturer of any liability for possible damages to objects or people. Do not remove or make inoperative the safety devices, this would cause a violation of safety at work laws and regulations.



Any other use which differs from that provided for by the manufacturer of the machine is strictly forbidden.



The use of non genuine parts may cause damage to people or objects.

2 CHAPTER 2 – PRODUCT IDENTIFICATION

The identification data of the machine are shown in the label placed on the frame and indicated in the declaration of conformity.

LOGO	
Type:
Model:
Serial Number:
Year of manufacturing:
Capacity:
Voltage:
Power:
Max. pressure:



Use the above data both to order spare parts and in case of enquires with the manufacturer (inquiry). The removal of this label is strictly forbidden.

Machines may be updated or slightly modified from an aesthetic point of view and, as a consequence, may present features different from these shown, this without prejudicing what has been described herein.

2.1 WARRANTY CERTIFICATE

The warranty is valid for a period of 12 months starting from the date of the purchase invoice. The warranty will end immediately when unauthorized modifications to the machine or parts of it are carried out.

The presence of defects in workmanship must be verified by the Manufacturer's personnel in charge.

2.2 TECHNICAL SERVICING

For all servicing and maintenance operations not specified or shown in these instructions, contact your Dealer where the machine was bought or the Manufacturer's Commercial Department.

3 CHAPTER 3 - PACKING, TRANSPORT AND STORAGE

Only skilled personnel who are familiar with the lift and this manual shall be allowed to carry out packing, lifting, handling, transport and unpacking operations.

3.1 PACKING

The lift is supplied disassembled into sub-assemblies depending on the model ordered.

Model N:

- N° 2 base units, each one with a flat runway and 2 hydraulic cylinders
- N° 1 control unit equipped with hydraulic unit;
- N° 1 box containing hydraulic lines, stickers and technical documentation;
- N° 2 drive-on ramps with 2 stop wheels and 4 protective devices to connect runways for on-floor installation or 4 drive-on ramps for in-ground installation.

Model AT:

- N° 2 base units, each one with a runway equipped with recessing for the graduated plates and slip plates for wheel alignment, and 2 hydraulic cylinders;
- N° 1 control unit equipped with hydraulic unit
- N° 1 box containing hydraulic lines, stickers and technical documentation;
- N° 2 drive-on ramps with 2 stop wheels and 4 protective devices to connect runways for on-floor installation or 4 drive-on ramps for in-ground installation.

Model LT:

- N° 2 base units, each one with a flat runway equipped with lift-table for further lifting of the vehicle, and 4 hydraulic cylinders;
- N° 1 control unit equipped with hydraulic unit
- N° 1 box containing hydraulic lines, stickers and technical documentation;
- N° 2 drive-on ramps with 2 stop wheels and 4 protective devices to connect runways for on-floor installation or 4 drive-on ramps for in-ground installation.

Model LTAT:

- N° 2 base units, each one with a flat runway equipped with recessing for the graduated plates and slip plates for wheel alignment, and lift-table for further lifting of the vehicle, and 4 hydraulic cylinders;
- N° 1 control unit equipped with hydraulic unit
- N° 1 box containing hydraulic lines, stickers and technical documentation;
- N° 2 drive-on ramps with 2 stop wheels and 4 protective devices to connect runways for on-floor installation or 4 drive-on ramps for in-ground installation.

If requested, optional accessories are available to satisfy each customer's requirements (Ref. accessories manual and price lists).

The lift is packed in a single box on a wooden bed, wrapped up in non-scratch waterproof material and sealed with 2 straps.

The average weight of the package changes between 2000 - 2600 Kg.

Figure 1 – MODELS TYPE

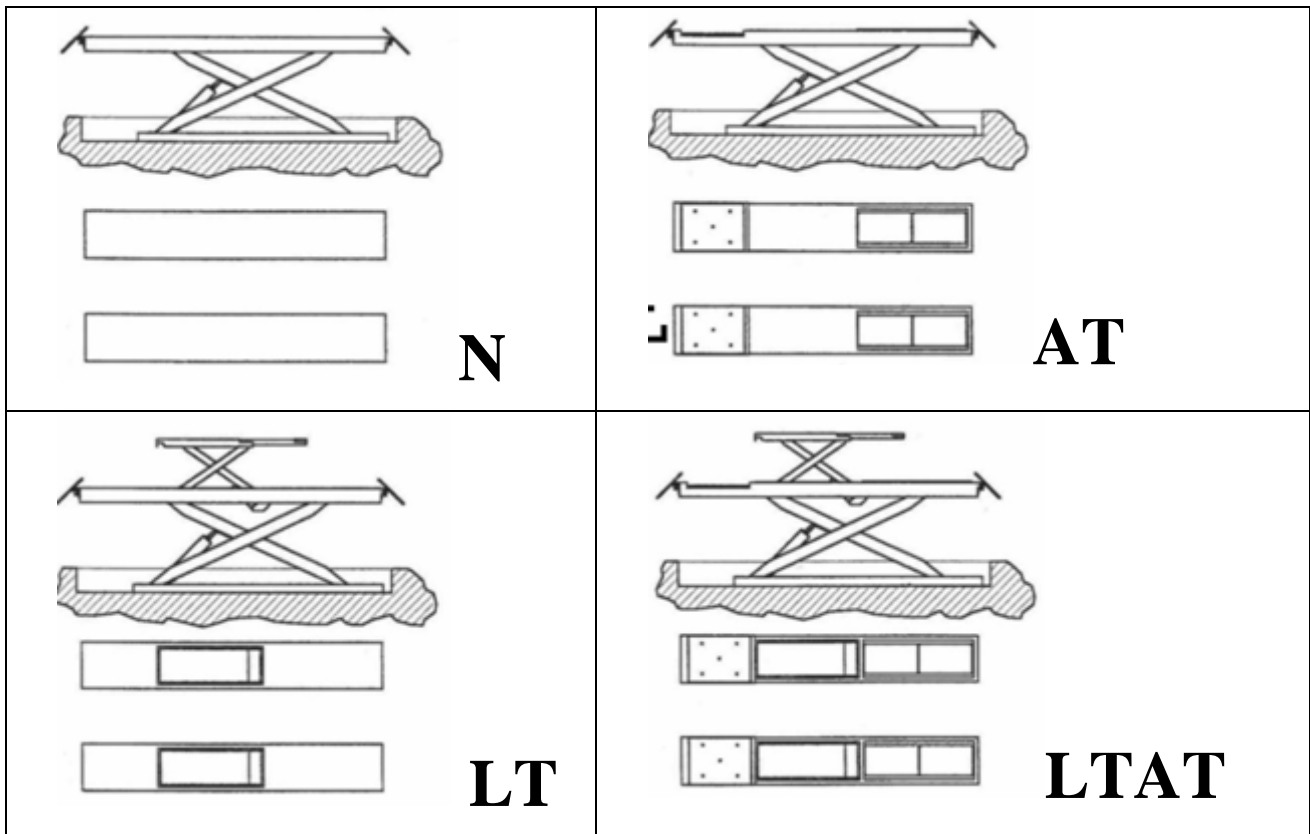

3.2 LIFTING AND HANDLING

When loading/unloading or transporting the equipment to the site, be sure to use suitable loading (e.g. cranes, trucks) and hoisting equipment. Hoist and transport the components securely so that they cannot drop, taking into consideration the package's size, weight and centre of gravity and fragile parts.

In figure 2 there are the correct indications for the lifting of the runways during the connecting cables phase:

1. runways lifting without play detector
2. runways lifting with support (ex. metal sheet) placed in the entry runway fixing plate
3. runways lifting with hydraulic play detector
4. lift lifting (pay attention to the hydraulic hoses).

Figure 2 – PACKAGE AND HANDLING

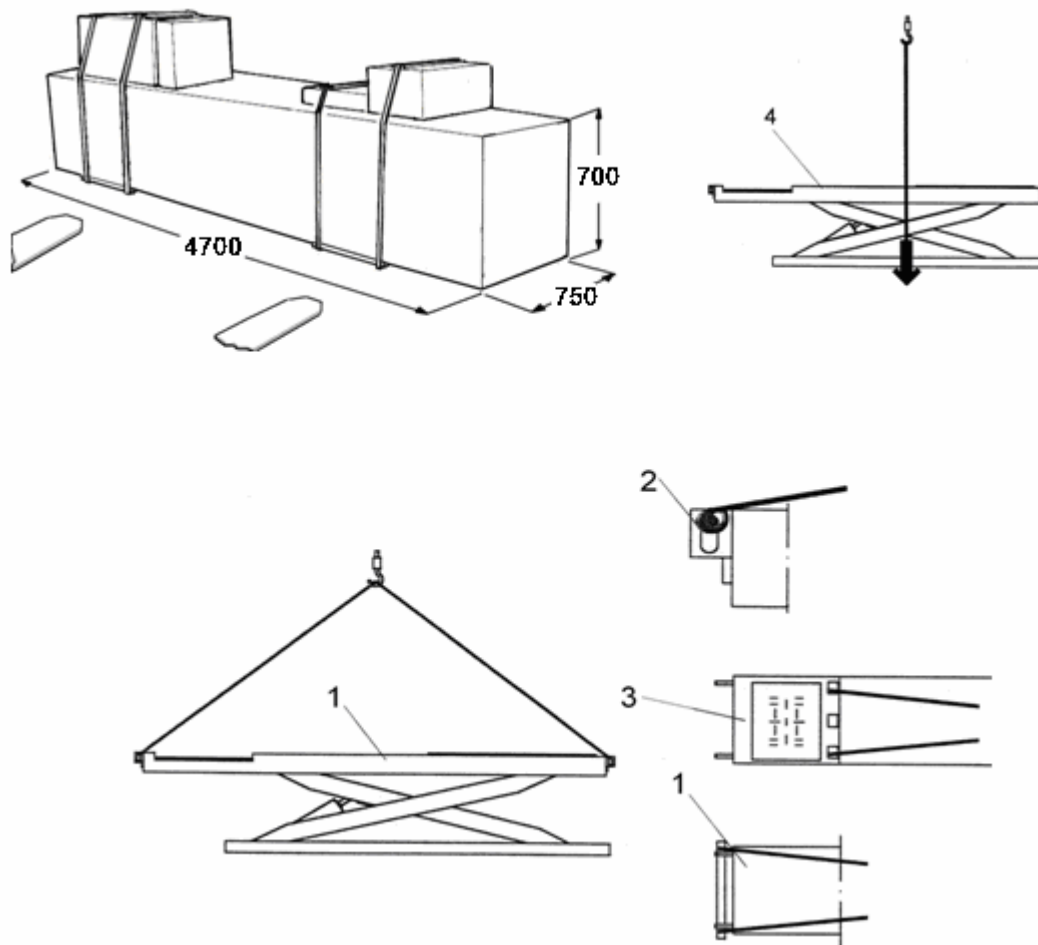

	Hoist and handle only one package at a time
--	--

3.3 STORAGE AND STACKING OF PACKAGES

Packages must be stored in a covered area, out of direct sunlight and in low humidity, at a temperature between -10°C and $+40^{\circ}\text{C}$.

Stacking is not recommended: the package's narrow base, as well as its considerable weight and size make it difficult and hazardous.

If this was necessary, never stack more than three packages a time and fix them with straps, ropes or other suitable means to ensure they are secure.

3.4 DELIVERY AND CHECKING OF PACKAGES

When the lift is delivered, check for possible damages due to transport and storage; verify its conformity with what is specified in the manufacturer's confirmation of order is included. In case of damage in transit, the customer must immediately inform the carrier of the problem.

Packages must be opened paying attention not to cause damage to people (keep a safe distance when opening straps) and parts of the lift (be careful the objects do not drop from the package when opening).

4 CHAPTER 4 - PRODUCT DESCRIPTION

4.1 LIFT (Ref. Figure 3)

All models have been designed to lift motor-vehicles at any level between the minimum and maximum height.

The maximum lifting weight, including any additional load on the vehicle, is as specified on the serial plate.

All mechanical frames, such as platforms, extensions, base frames and arms have been built in a pressure bend plant to make the frame rigid and strong while keeping a low weight

The electro hydraulic operation is described in detail in chapter 8

As shown in figure 3, the lift is composed of two platforms, the platform 1 (1) and the platform 2 (2) anchored to the ground by means of two base frames (3)

The lift is equipped with 4 drive-up ramps (4) at the end of the platforms to facilitate the entry the of vehicle.

Platforms, linked to the base frame by means of a scissors lifting system, is 4200 mm in length and the lifting system of each platform is composed of two arms, external (5) and internal (6), as well as a cylinder primary (7) in platform P1, and a secondary cylinder (8) in platform P2.

On both cylinders are installed mechanical safety devices. (9).

Lift lowering and lifting are carried out by means of a control box (17) (fixed to the ground) next to the lift.

Models LT and LTAT, are equipped with an auxiliary lift or lift-table,(10) for further lifting of the vehicle. Two cylinders (11) for platform P1 and (12) for platform P2 raise the auxiliary lift.

On both cylinders are installed mechanical safety devices. (13).

Auxiliary lift platforms are equipped with extensions. (14).

Models LT e LTAT are equipped with slip plates (15) and recess for turn plates (16).

Figure 3 - LIFT

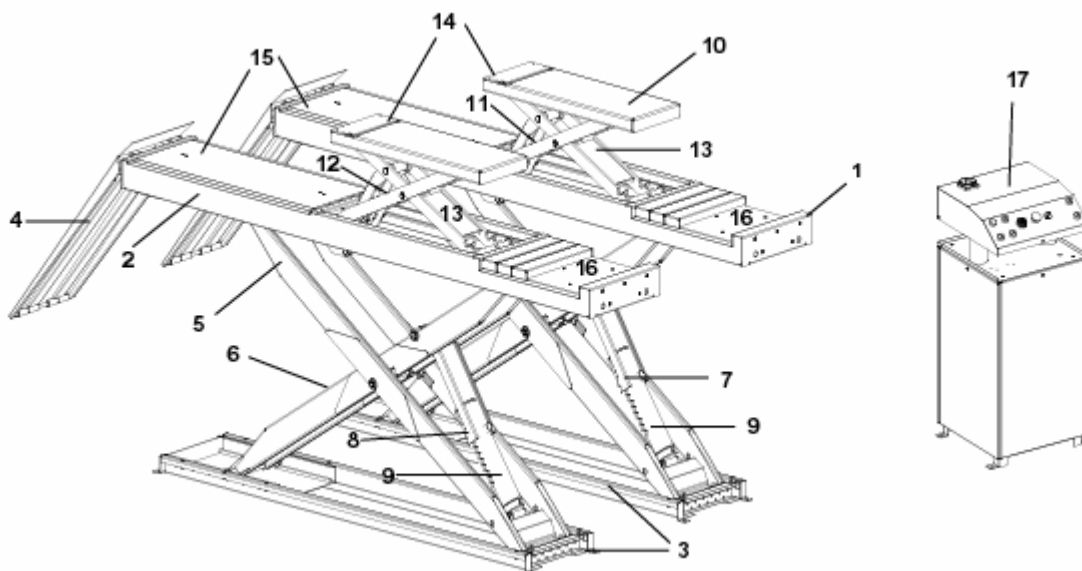

4.2 SENSORS

Model “N”

On model “N” following sensors are installed:

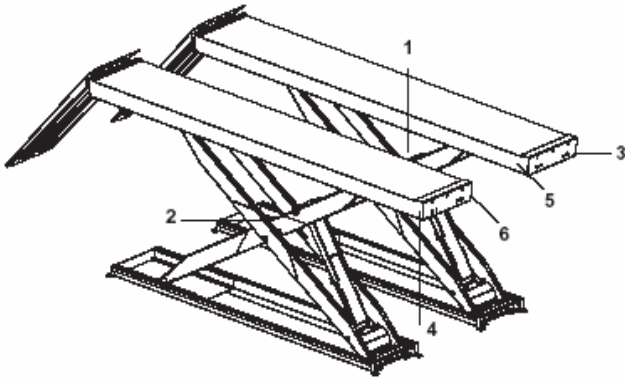

- (1) The proximity switch is placed between P1 Platform scissors to stop the lift at the safety height (400 mm);
- (2) the proximity switch is placed between P2 platform scissors to stop the lift at the maximum height
- (3) The leveling system limit switch for platform P1 is under the runway on left external side.
- (4) The leveling system limit switch for platform P2 is under the runway on right external side.
- (5) The photocell is locate don internal side of platform P1.
- (6) The reflector is located in the internal side of platform P2

Model “AT”

On model “AT” following sensors are installed::

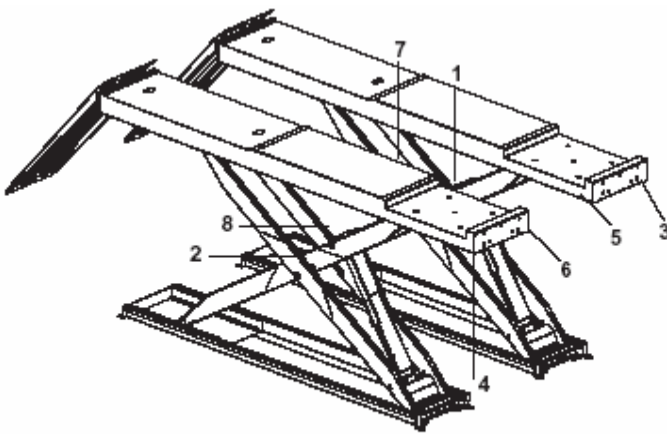

- (1) The proximity switch is placed between P1 Platform scissors to stop the lift at the safety height (400 mm);
- (2) the proximity switch is placed between P2 platform scissors to stop the lift at the maximum height
- (3) The leveling system limit switch for platform P1 is under the runway on left external side.
- (4) The leveling system limit switch for platform P2 is under the runway on right external side.
- (5) The photocell is locate don internal side of platform P1.
- (6) The reflector is located in the internal side of platform P2
- (7) Limit switch for 1st working position is located on internal arm of platform P1
- (8) Limit switch for 2nd working position is located on internal arm of platform P2

Model “LT”

On model “LT” following sensors are installed::

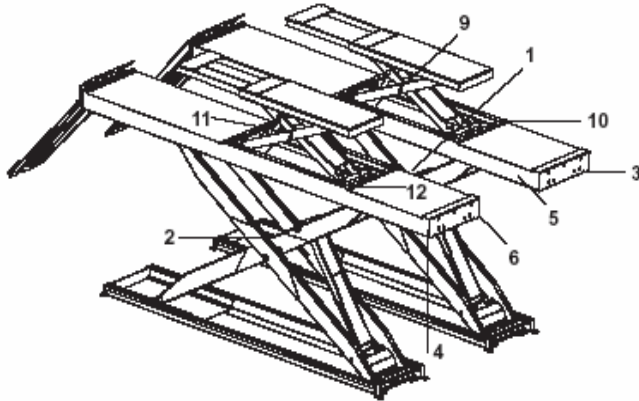

- (1) The proximity switch is placed between P1 Platform scissors to stop the lift at the safety height (400 mm);
- (2) the proximity switch is placed between P2 platform scissors to stop the lift at the maximum height
- (3) The leveling system limit switch for platform P1 is under the runway on left external side.
- (4) The leveling system limit switch for platform P2 is under the runway on right external side.
- (5) The photocell is located on internal side of platform P1.
- (6) The reflector is located in the internal side of platform P2
- (9) Safety height (130 mm) for auxiliary lift sensor is installed on arms of platform P1
- (10) Auxiliary lift platform P1 leveling sensor, is installed on of auxiliary lift platform P1 base frame;
- (11) Auxiliary lift maximum height limit switch, is installed on of auxiliary lift external arm P2;
- (12) Auxiliary lift platform P2 leveling sensor, is installed on of auxiliary lift platform P2 base frame;

Model “LTAT”

On model “LTAT” following sensors are installed::

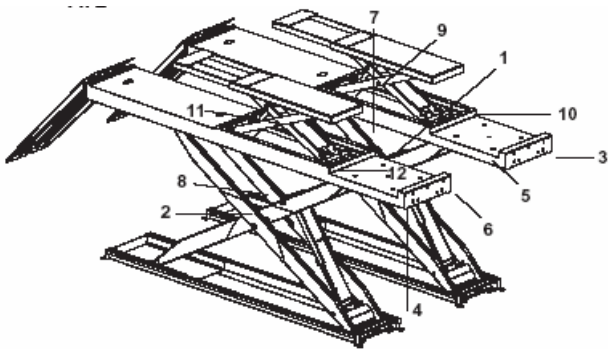

- (1) The proximity switch is placed between P1 Platform scissors to stop the lift at the safety height (400 mm);
- (2) the proximity switch is placed between P2 platform scissors to stop the lift at the maximum height
- (3) The leveling system limit switch for platform P1 is under the runway on left external side.
- (4) The leveling system limit switch for platform P2 is under the runway on right external side.
- (5) The photocell is located on internal side of platform P1.
- (6) The reflector is located in the internal side of platform P2
- (7) Limit switch for 1st working position is located on internal arm of platform P1
- (8) Limit switch for 2nd working position is located on internal arm of platform P2
- (9) Safety height (130 mm) for auxiliary lift sensor is installed on arms of platform P1
- (10) Auxiliary lift platform P1 leveling sensor, is installed on of auxiliary lift platform P1 base frame;
- (11) Auxiliary lift maximum height limit switch, is installed on of auxiliary lift external arm P2;
- (12) Auxiliary lift platform P2 leveling sensor, is installed on of auxiliary lift platform P2 base frame

4.3 CONTROL DESK

The Control desk is composed of a frame (1) covered with panels (2) and a top panel (3).

The control panel (4) is placed on the front of the top panel and is equipped with:

Double function button:

- Mechanical safety insertion / final lowering (last 400 mm.) (5)
- Pilot lamp (6)
- Up push button (7)
- Down push button (8)
- Emergency button (9)
- Beeper (10)
- 0/1 Selector (lift / auxiliary lift) only models “LT” e “LTAT” (11)
Whenever the lift is equipped with play detectors the selector (11) has 3 positions
- Main switch (12)
- 1st working position push button (13)
- 2nd working position push button (14)

The limit switches (height limit stop runway, height limit stop lift-table and runway photocell) override button (15) is placed inside the control desk, under the electric panel..

Main hydraulic unit (16) is placed in the lower parts of the control box .

The hydraulic unit is made of : oil tank (17), hydraulic pump (18) electric motor (19), solenoid valve (20) and hydraulic hoses.

Figure 4 – CONTROL DESK

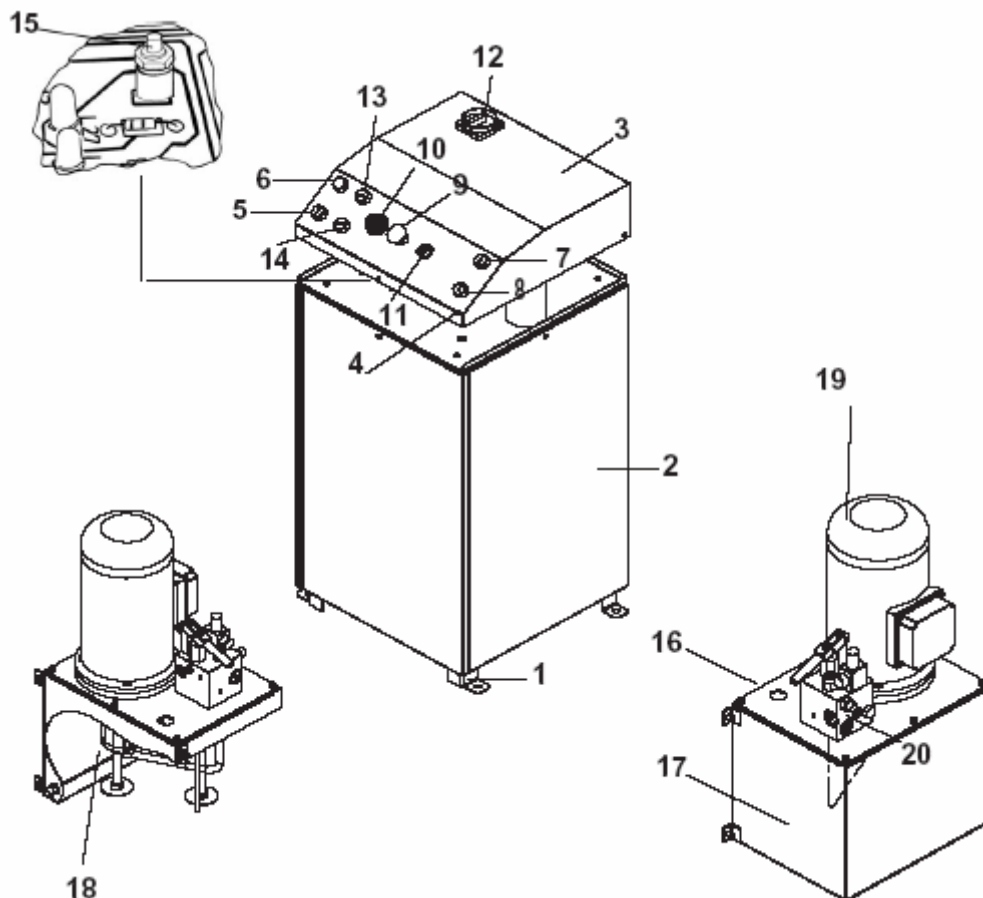

4.4 OPERATION

Platform lifting is carried out by the hydraulic unit which acts upon the primary cylinders.

Lowering, even though electrically controlled, is carried out by the weight of both the platforms and the load lifted.

The hydraulic system is protected by a maximum pressure control valve thus preventing pressure from exceeding the maximum fixed safety limit.

The lifting and lowering motion of the lift is controlled by the buttons on the control desk panel.

Whenever the lift has to be lowered to the ground and the DOWN button is pressed, the lift will stop at about *400 mm* from the ground.

In this way, the operator must verify that neither persons nor objects are within the safety area.

In this case, the FINAL LOWERING button can be pressed and the lift be lowered.

A beep sound is heard during the last travel.

Note: auxiliary lift on models “AT” e “LTAT”, has similar functioning to main lift, except lowering up to safety height (130 mm) which is electrically controlled.

5 CHAPTER 5 - TECHNICAL SPECIFICATION

5.1 SIZE AND MAIN FEATURES (Ref. Figure 5)

Capacity	5000 Kg
Maximum lifting height	1850 mm
Minimum height of lift	360 mm
Length of the lift	4600/5200 mm
Width of the lift	~ 2250* mm
Width of platforms	668 mm (N-LT) / 704 mm (AT-LTAT)
Free width between platforms	886* mm (N-LT) / 850* mm (AT-LTAT)
Lifting time	~ 60 s
Lowering time	~ 60 s
Noise level	70 dB(A)/1m
Total weight of the lift	Kg.1800(N)-1900(AT) 2400(LT)-2500(LTAT)
Working temperature	-10 °C ÷ 40 °C
Compressed air pressure	6 bar

5.2 ELECTRIC MOTOR

Type	90LA/4
Power	3 KW
Voltage	230 V / 400V
Frequency	50 Hz
N° Poles	4
Speed	1400 rpm
Motor enclosure type	B5
Insulation class	IP 54
Amperage	13.5 A a 230 V 8 A a 400 V

Motor connection must be carried out referring to the attached wiring diagrams (rif. Figura 6).
The motor direction of rotation is shown in the label placed on the motor.

5.3 PUMP

Type	gear
Flow rate	5 cm ³ /g
Continuous working pressure	210 bar
Frequent working pressure	230 bar
Peak pressure	245 bar

Figure 5a – LAYOUT MIRACH 50 N

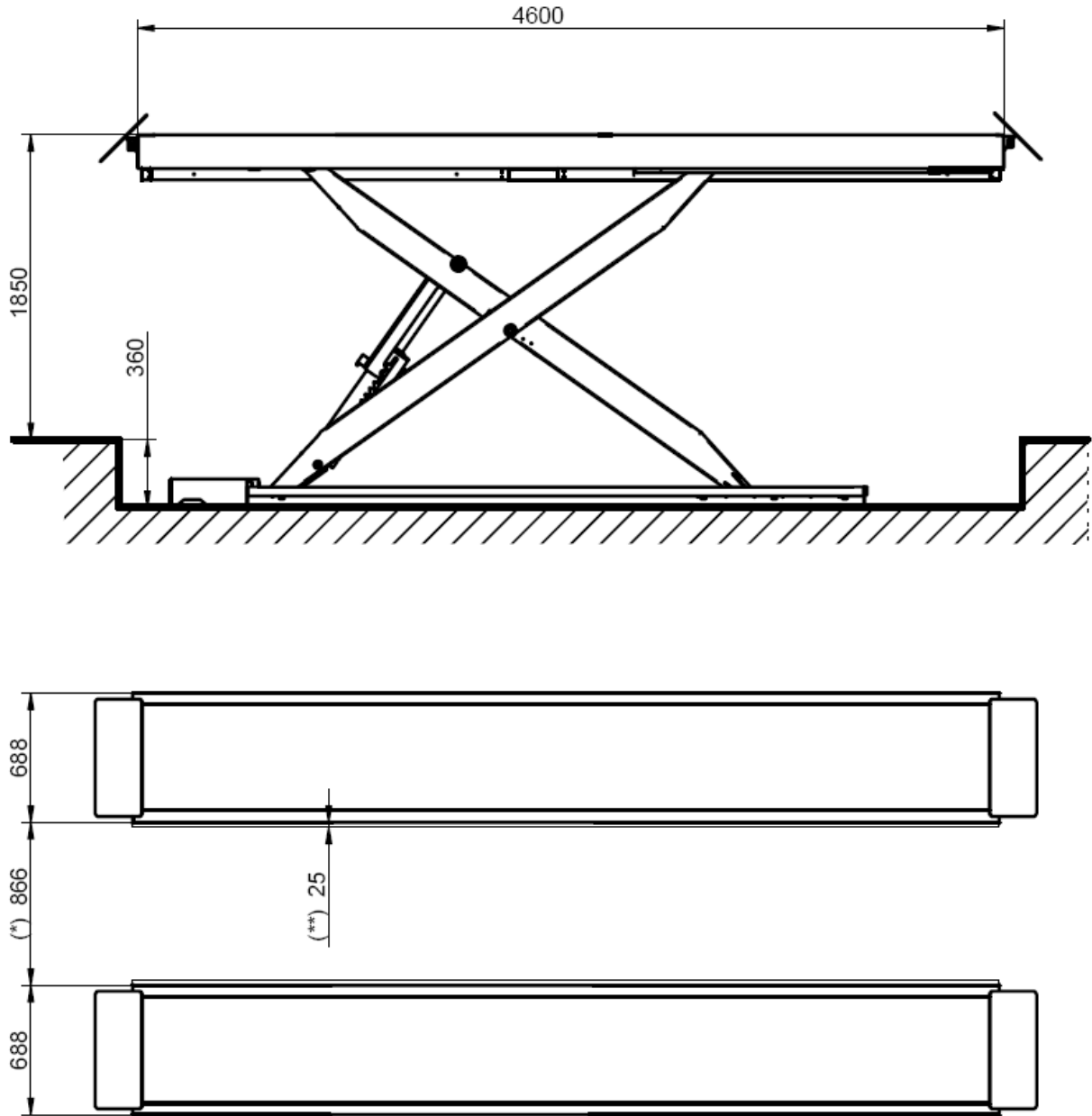

- (*) Suggested dimension
- (**) Guide

Figure 5b – LAYOUT MIRACH 50 AT

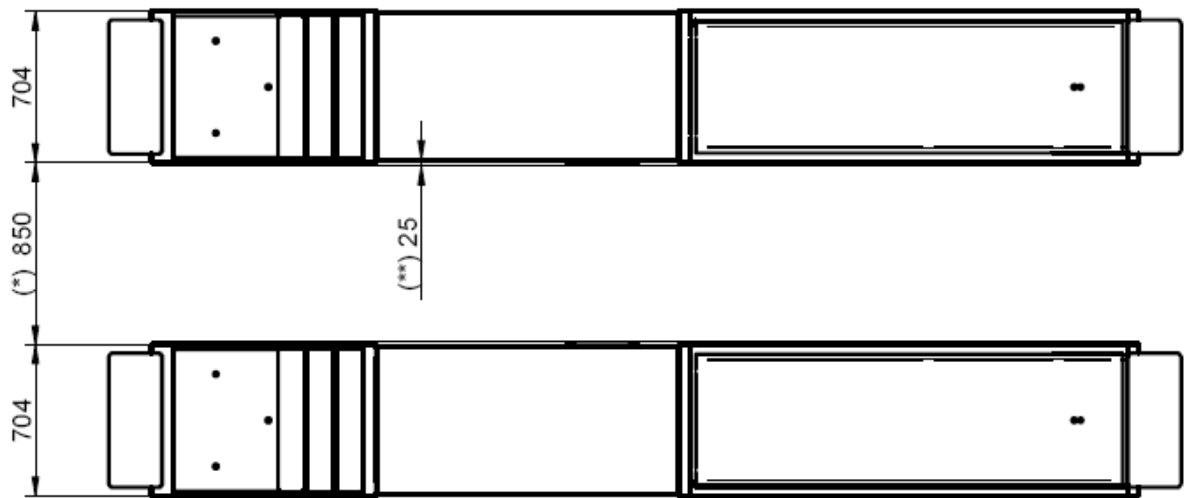
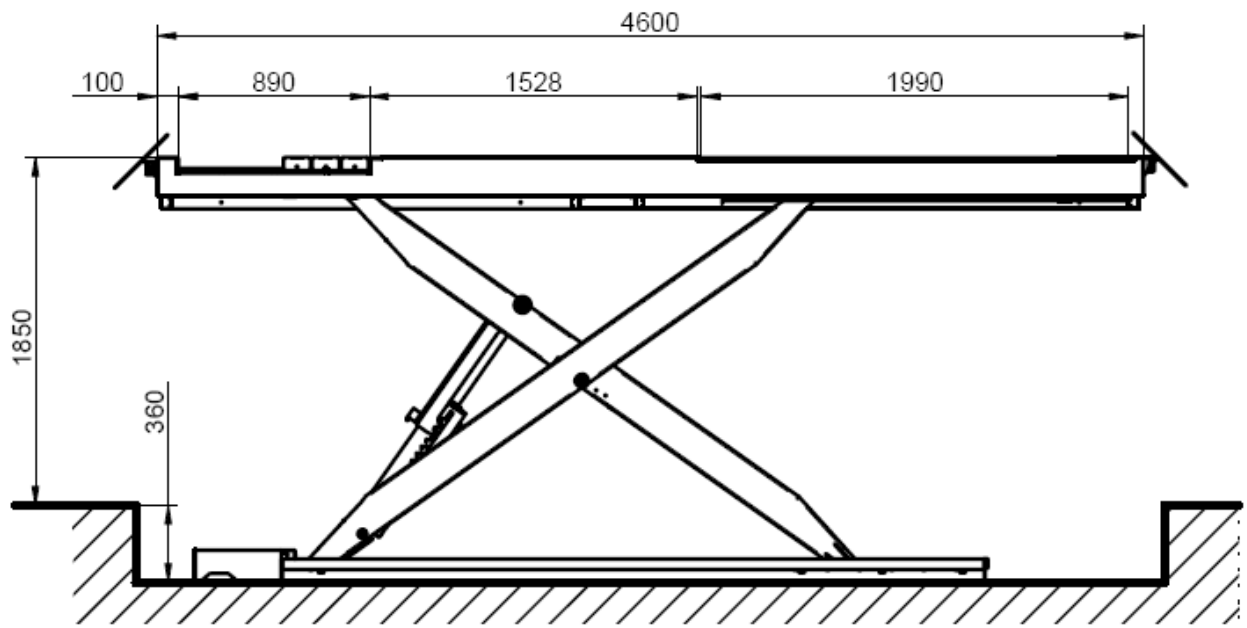

(* Suggested dimension

(** Guide

Figure 5c – LAYOUT MIRACH 50 LT

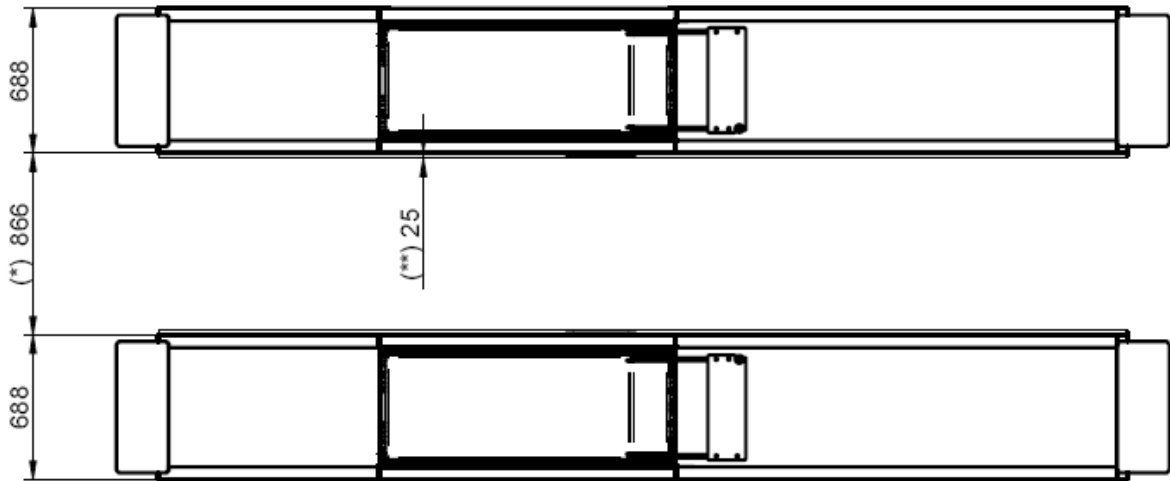
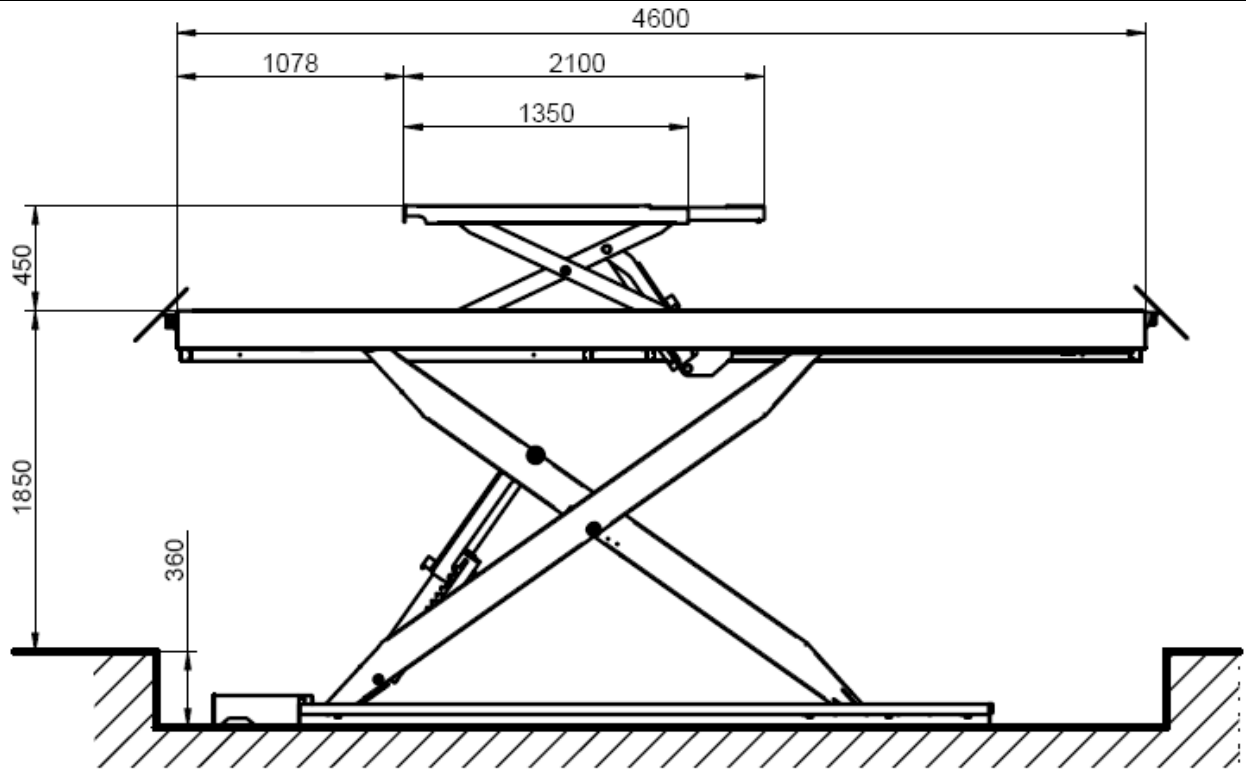

(* Suggested dimension

(**) Guide

Figure 5d – LAYOUT MIRACH 50 LTAT

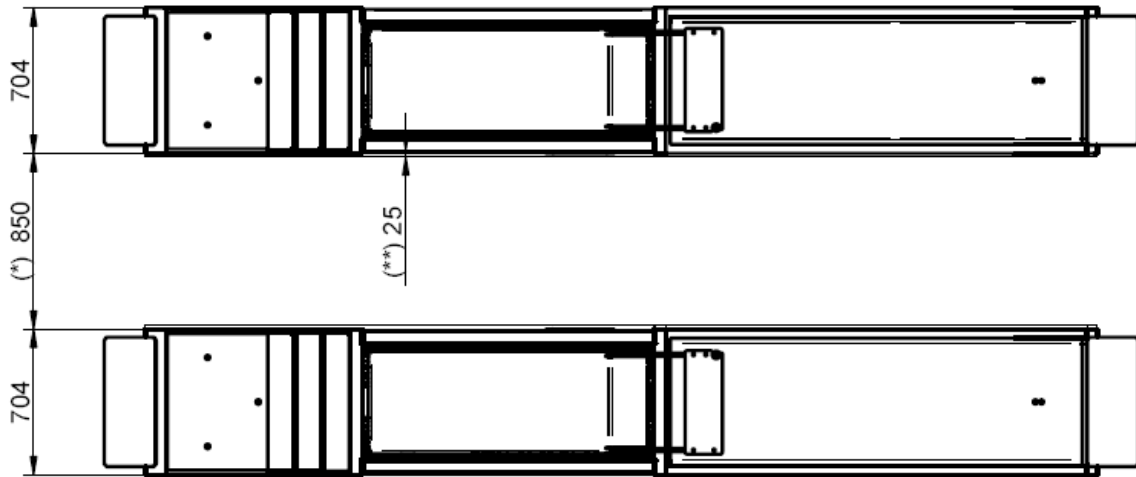
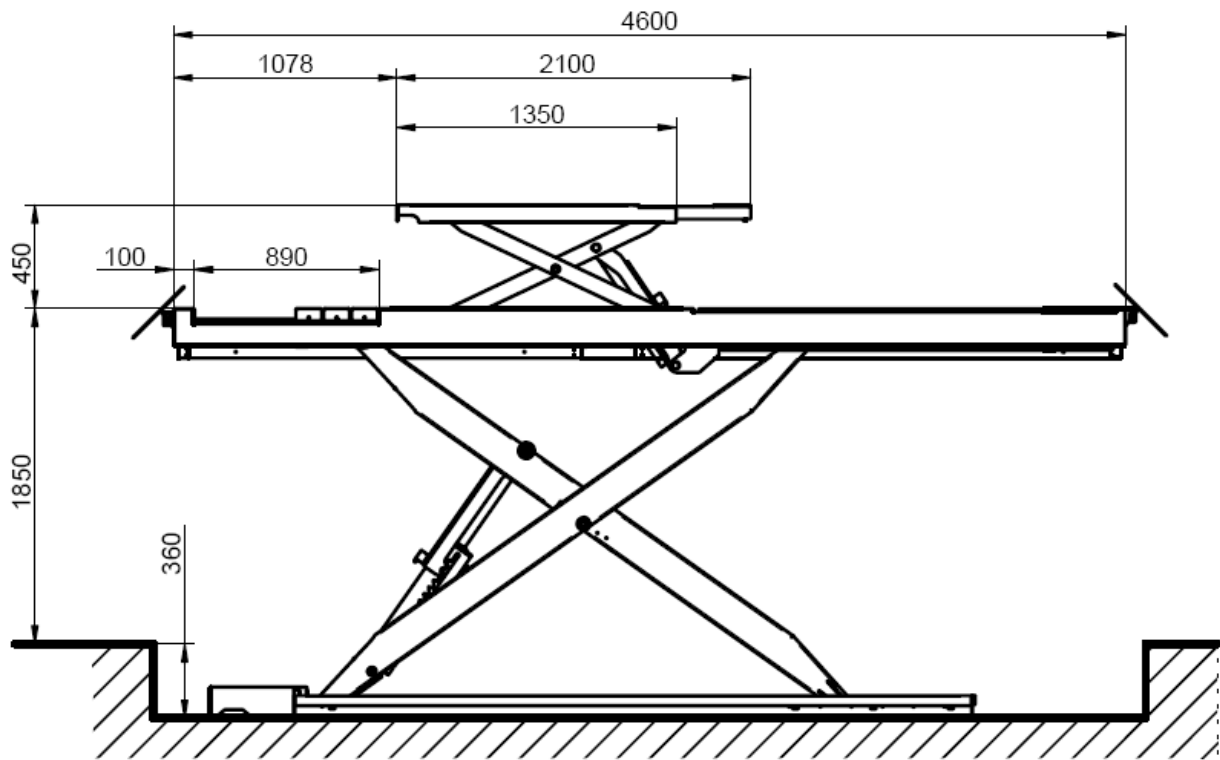

(*) Suggested dimension
(**) Guide

5.4 HYDRAULIC UNIT

Hydraulic unit changes according to models:

“N” and “AT” models are equipped with aluminum block on which are installed :

- (1) not used
- (2) platforms leveling solenoid valve (EV2)
- (3) platform lowering solenoid valve (EV3)
- (4) platform commutation solenoid valve (EV4)
- (5) max pressure valve
- (6) check valve
- (7) platform lowering control valve
- (8) not used
- (9) hand pump

Figure 6 – HYDRAULIC BLOCK

MODELS “N” AND “AT”

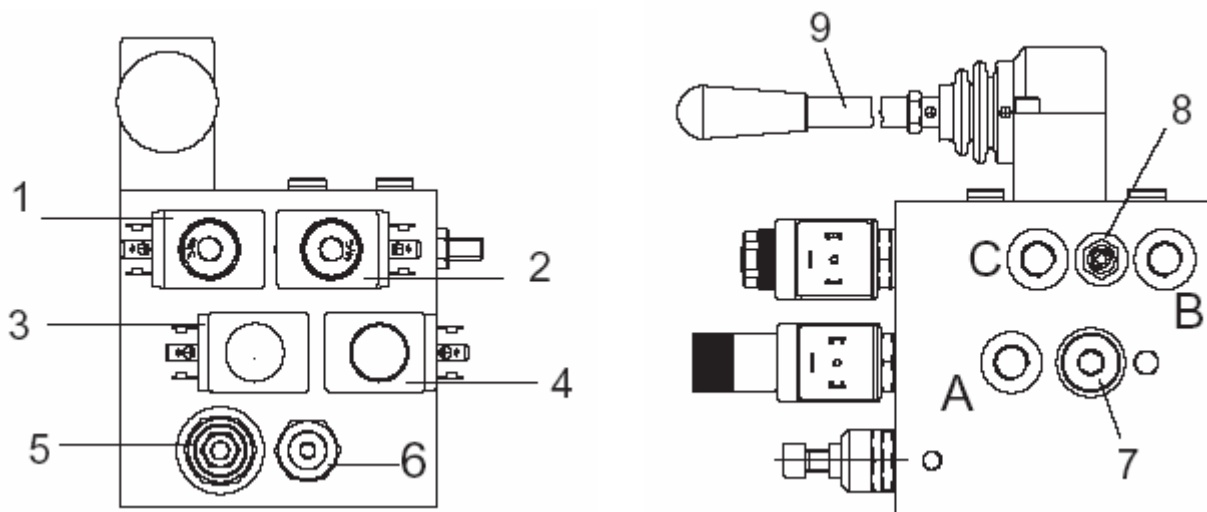

Figure 7 – HYDRAULIC BLOCK

“LT” and “LTAT” models are equipped with aluminium block on which are installed :

- (1) auxiliary lift leveling solenoid valve (EV 8)
- (2) auxiliary lift switching solenoid valve (EV 6)
- (3) platform lowering solenoid valve (EV 3)
- (4) auxiliary lift lowering solenoid valve (EV 7)
- (5) platform leveling solenoid valve (EV 2)
- (6) platform switching solenoid valve (EV 4)
- (7) max pressure valve
- (8) check valve
- (9) platform lowering control valve
- (10) auxiliary lift manual lowering valve
- (11) auxiliary lift max pressure valve
- (12) hand pump

Pressure gauges connections A1 and C1 are located on hydraulic block side , for both the platform and the auxiliary lift.

Modelli “LT” e “LTAT”

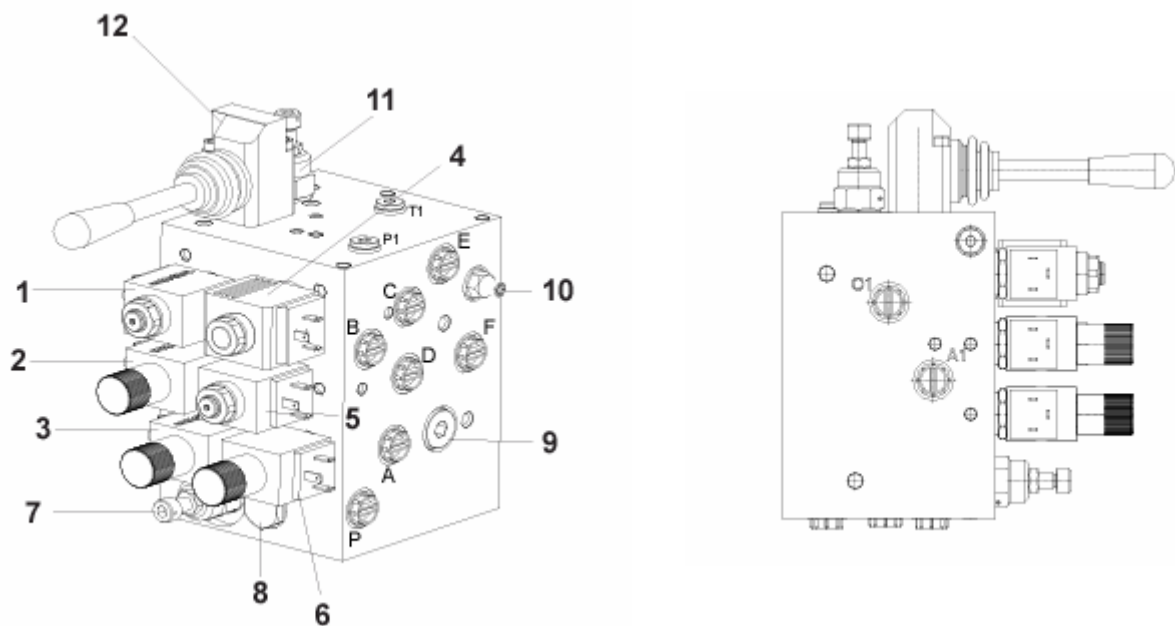

5.5 OIL

Use wear proof oil for hydraulic drive, in conformity with *ISO 6743/4* rules (HM class). *Fina HYDRAN TS 32* or equivalent oil with features similar to those shown in the table is recommended:

TEST STANDARDS	FEATURES	VALUE
ASTM D 1298	Density 20°C	0.8 kg/l
ASTM D 445	Viscosity 40°C	32 cSt
ASTM D 445	Viscosity 100°C	5.43 cSt
ASTM D 2270	Viscosity index	104 N°
ASTM D 97	Pour point	~ 30 °C
ASTM D 92	Flash point	215 °C
ASTM D 644	Neutralization number	0.5 mg KOH/g

In case where the average ambient temperature differs from 25° C contact your local specialist oil supplier to find a suitable substitute.

5.6 RECOMMENDED HYDRAULIC OIL

Recommended hydraulic oil for the lift to be used at standard temperatures (25°C - 30°C) is described below.

For temperatures different from those standard, contact your dealer for suitable oil.

BRAND	TYPE
AGIP	OSO 32
API	CIS 32
BP	HLP 32
CASTROL	HYSPIN HWS 32
ELF	ELFONA DS 32
ESSO	NUTO H 32
FIAT	HTF 32
FINA	HYDRAN TS 32
IP	HYDRUS 32
Q8	HAYDYN 32
MOBIL	DTE 24
ROL OIL	LI 32
SHELL	TELLUS OIL 32
TOTAL	AZOLLA ZS 32



CHANGE HYDRAULIC OIL EVERY 5 YEARS

Figure 8 – HYDRAULIC PLANT
MODELS “N” AND “AT”

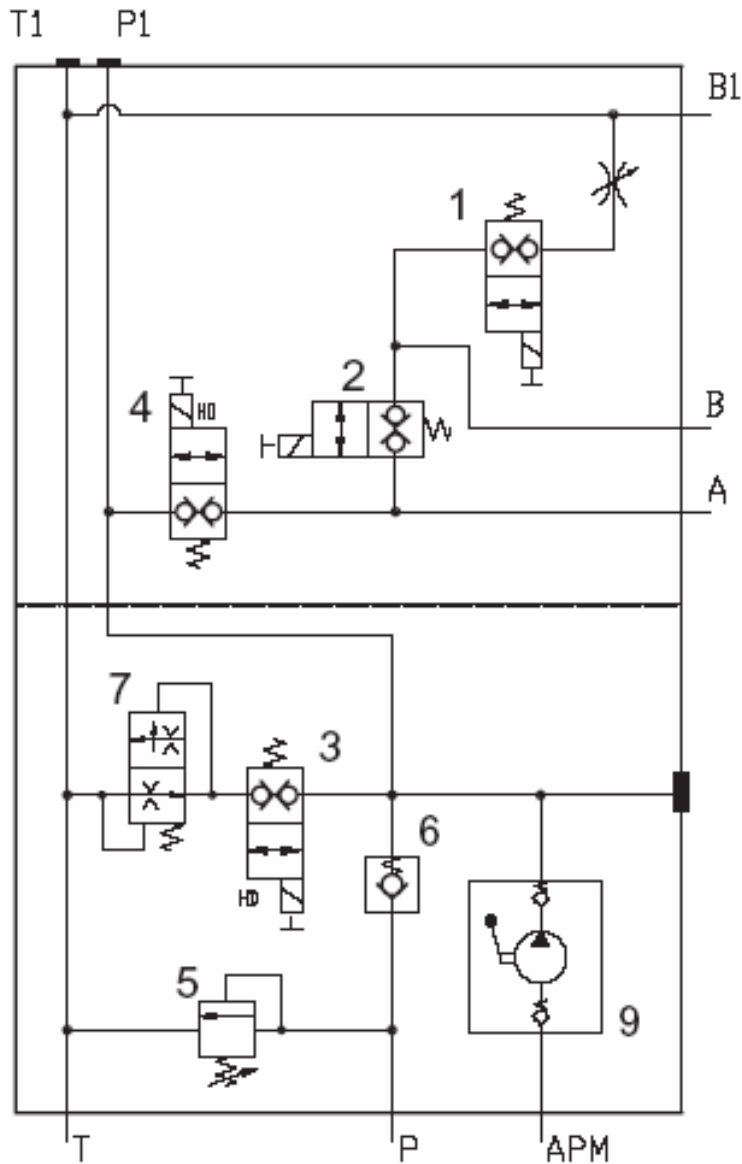

- 1 not used
 - 2 platform leveling solenoid valve (EV2)
 - 3 platform lowering solenoid valve (EV3)
 - 4 platform switching solenoid valve (EV4)
 - 5 max pressure valve
 - 6 check valve
 - 7 platform lowering control valve
 - 8 not used
 - 9 hand pump
- A Platform P1 cylinder delivery
 - B Platform P1 cylinder return, P2 cylinder delivery
 - B1 Platform P2 cylinder return

Figure 9 – HYDRAULIC PLANT MODELS “LT” AND “LTAT”

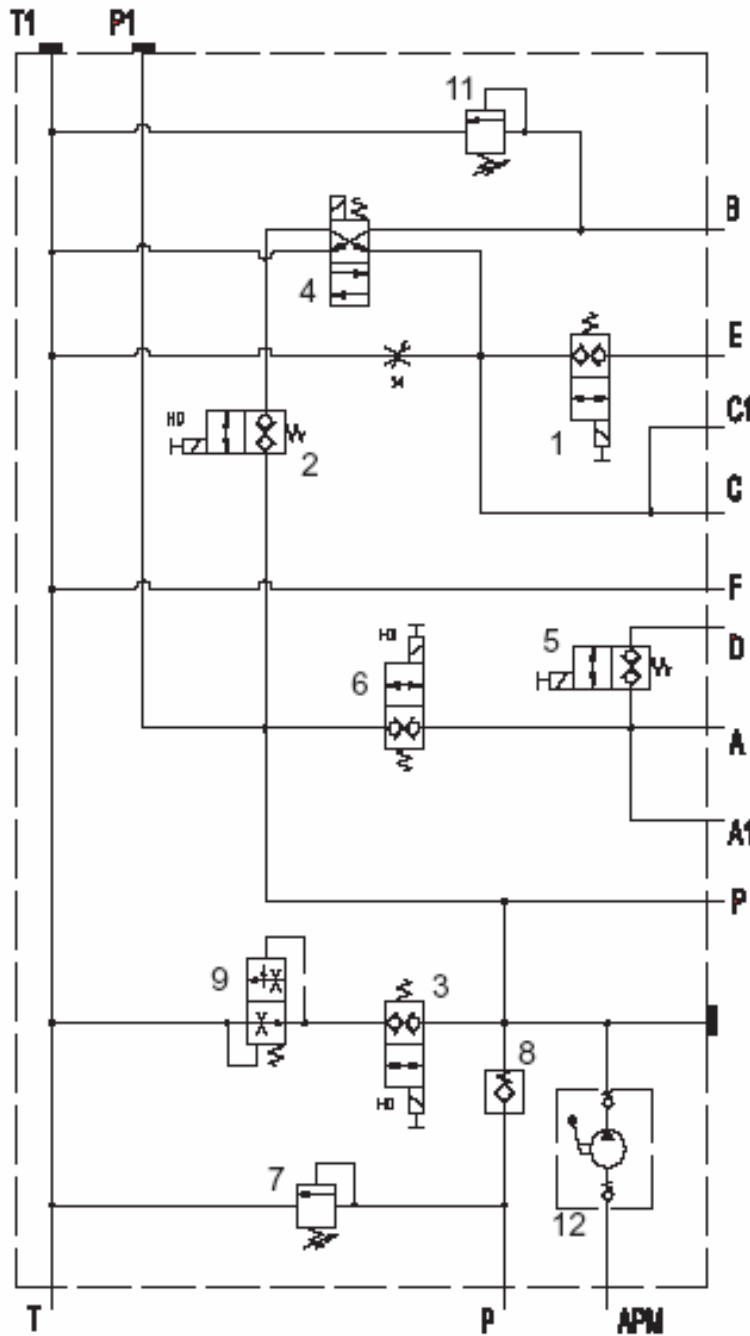

- 1 auxiliary lift leveling solenoid valve (EV 8)
 - 2 auxiliary lift switching solenoid valve (EV 6)
 - 3 platform lowering solenoid valve (EV 3)
 - 4 auxiliary lift lowering solenoid valve (EV 7)
 - 5 platform leveling solenoid valve (EV 2)
 - 6 platform switching solenoid valve (EV 4)
 - 7 max pressure valve
 - 8 check valve
 - 9 platform lowering control valve
 - 10 auxiliary lift manual lowering valve
 - 11 auxiliary lift max pressure valve
 - 12 hand pump
- A Platform P1 cylinder delivery
 - A1 Platform pressure gauge connection
 - B Auxiliary lift P2 cylinder return
 - C Auxiliary lift P1 cylinder delivery
 - C1 Auxiliary lift pressure gauge connection
 - D Platform P1 cylinder return , platform P2 cylinder delivery
 - E Auxiliary lift P1 cylinder return, P2 cylinder delivery
 - F Platform P2 cylinder return
 - P 8M Play detector delivery

Figure 10a – ELECTRIC WIRING

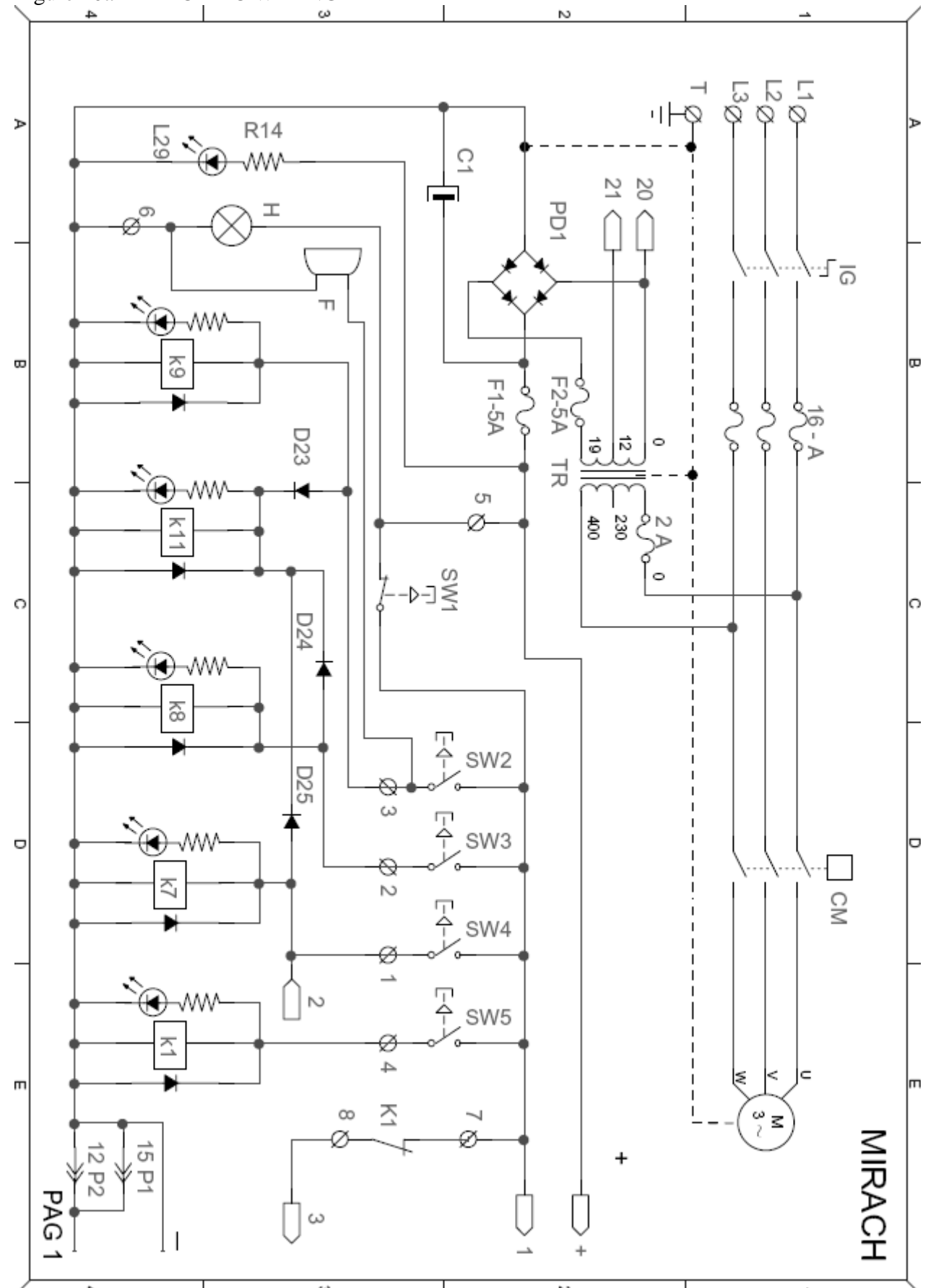

Figure 10b – ELECTRIC WIRING

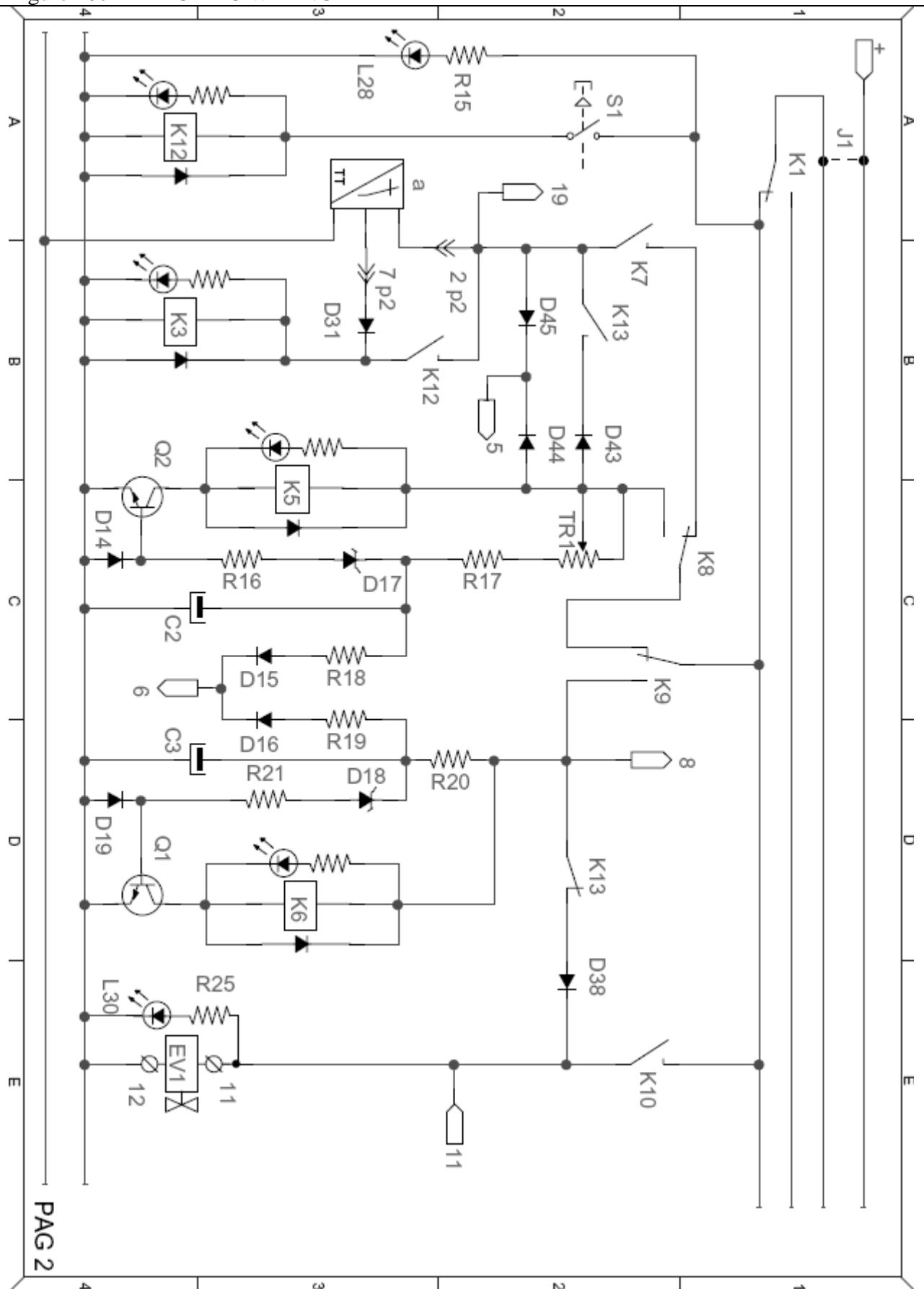

Figure 10c – ELECTRIC WIRING

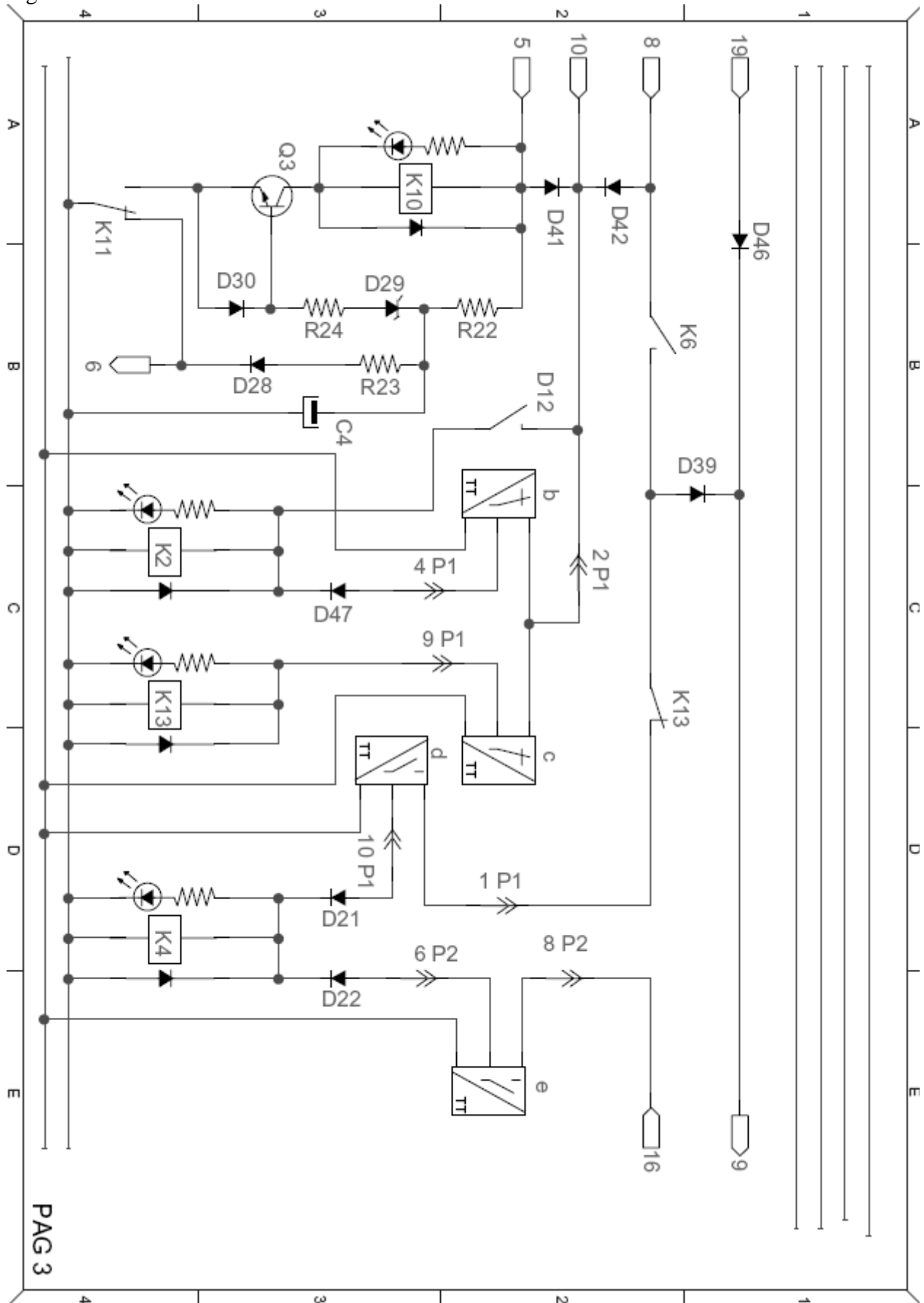

Figure 10d – ELECTRIC WIRING

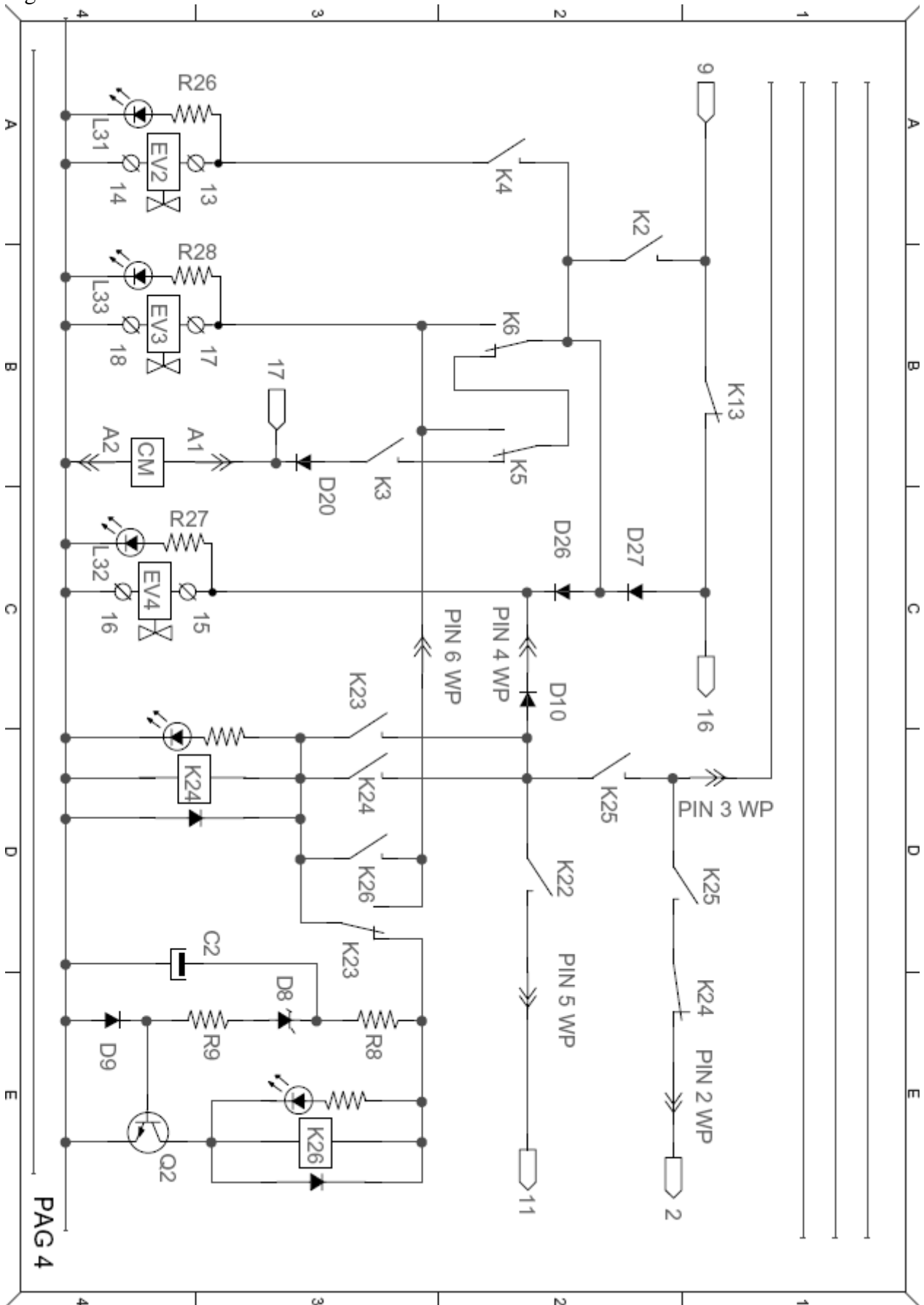

Figure 10e – ELECTRIC WIRING

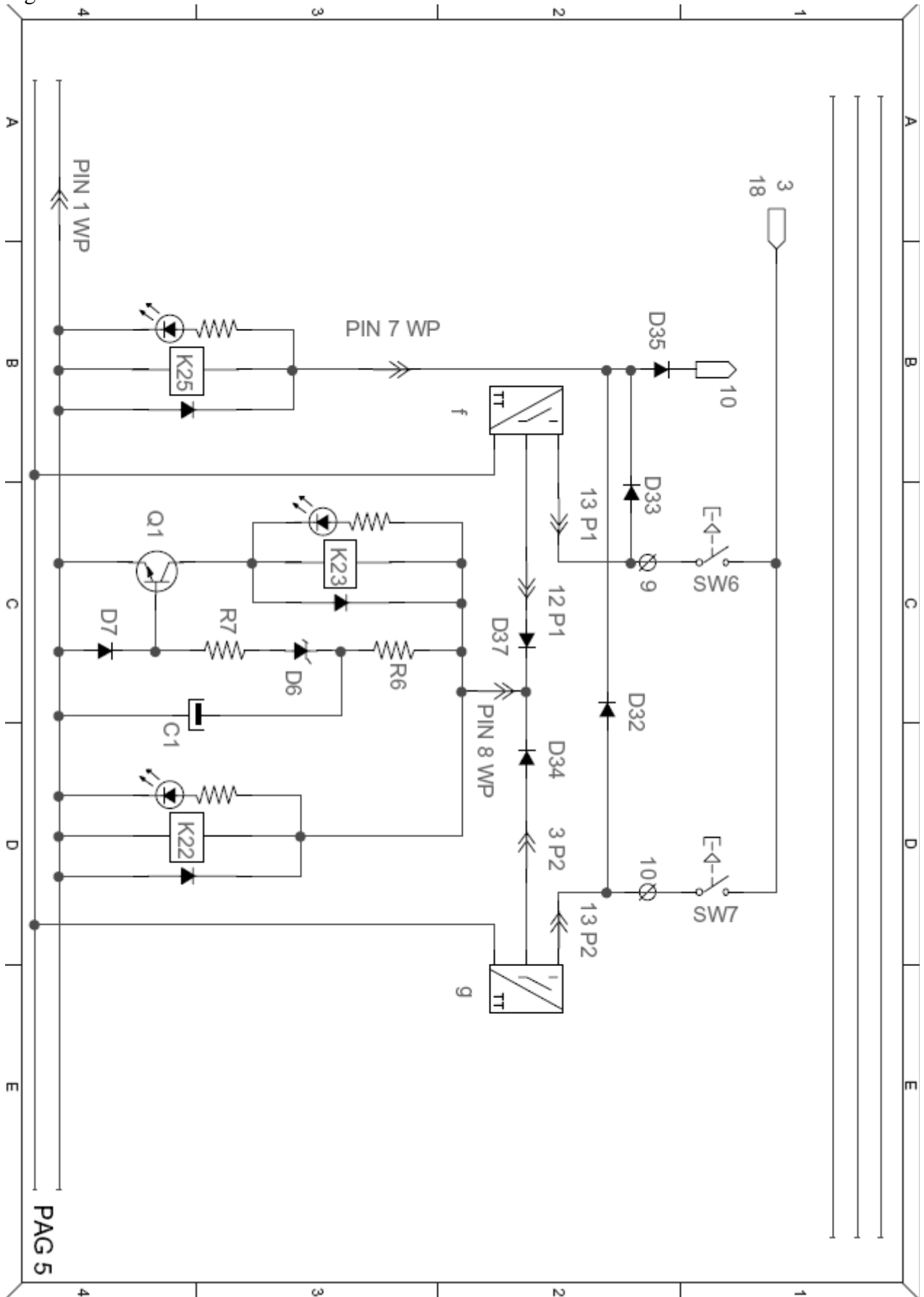

Figure 10f – ELECTRIC WIRING

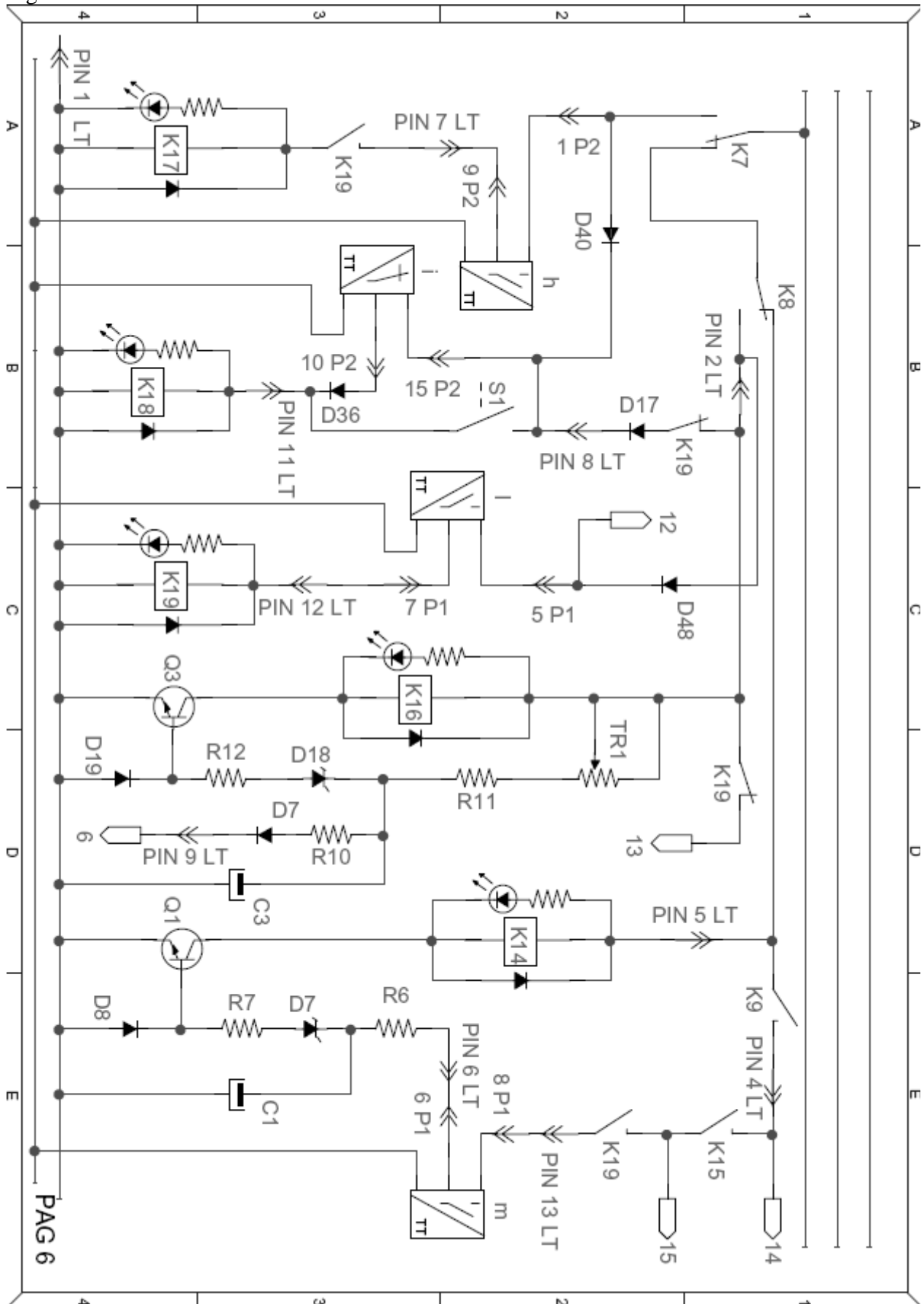

Figure 10g – ELECTRIC WIRING

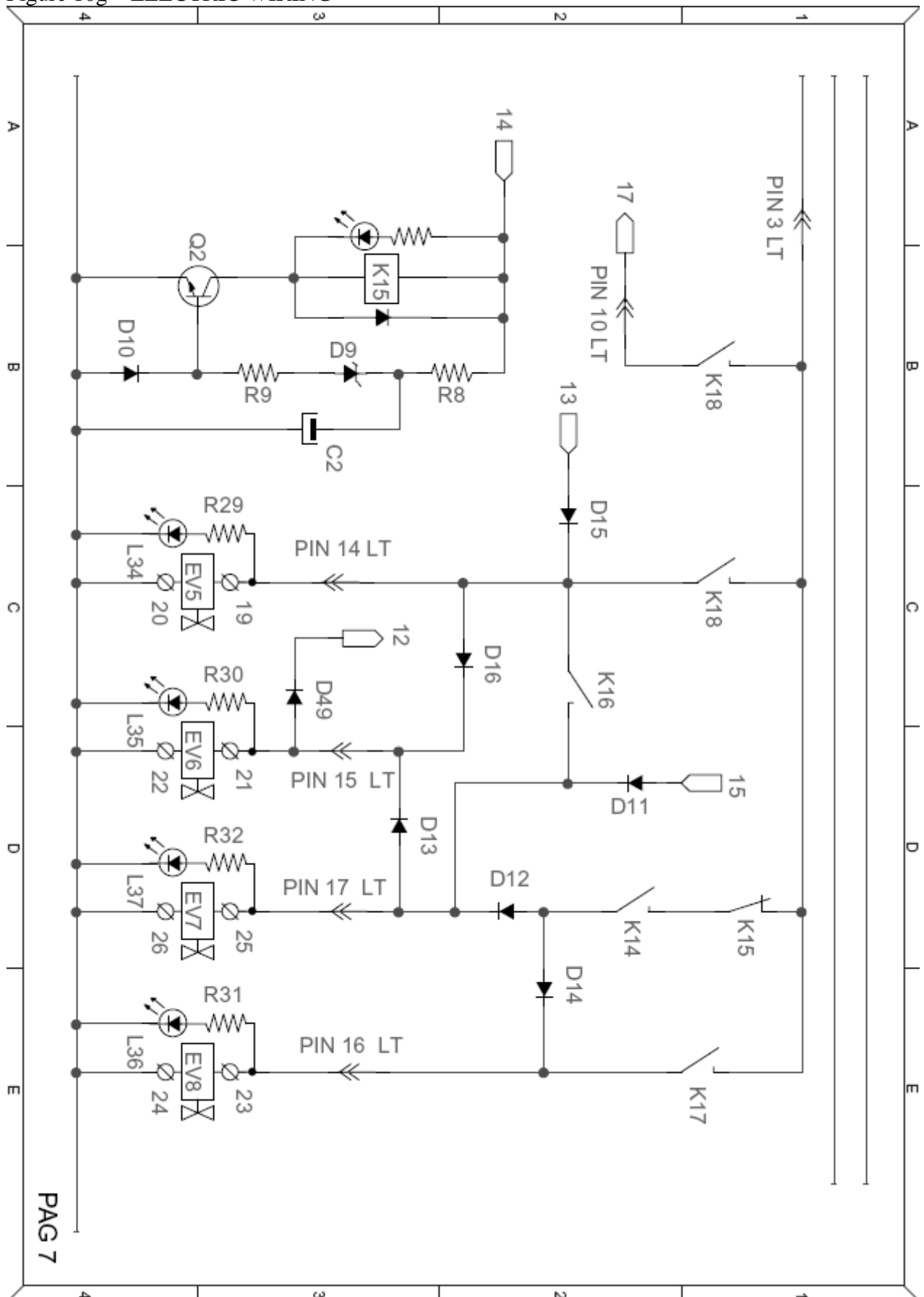

Figure 10h – ELECTRIC WIRING

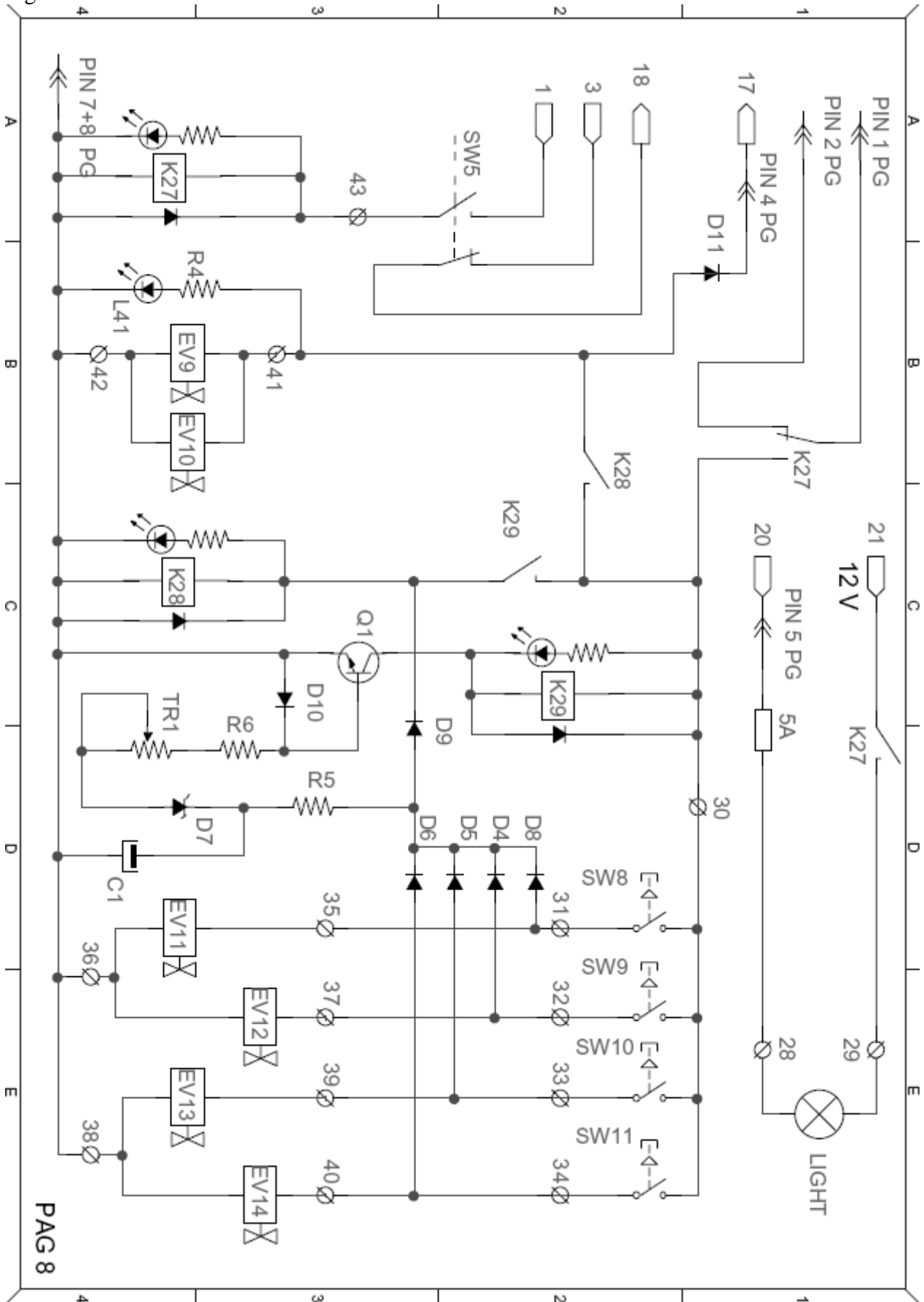

Figure 10i – ELECTRIC WIRING – terminals connections

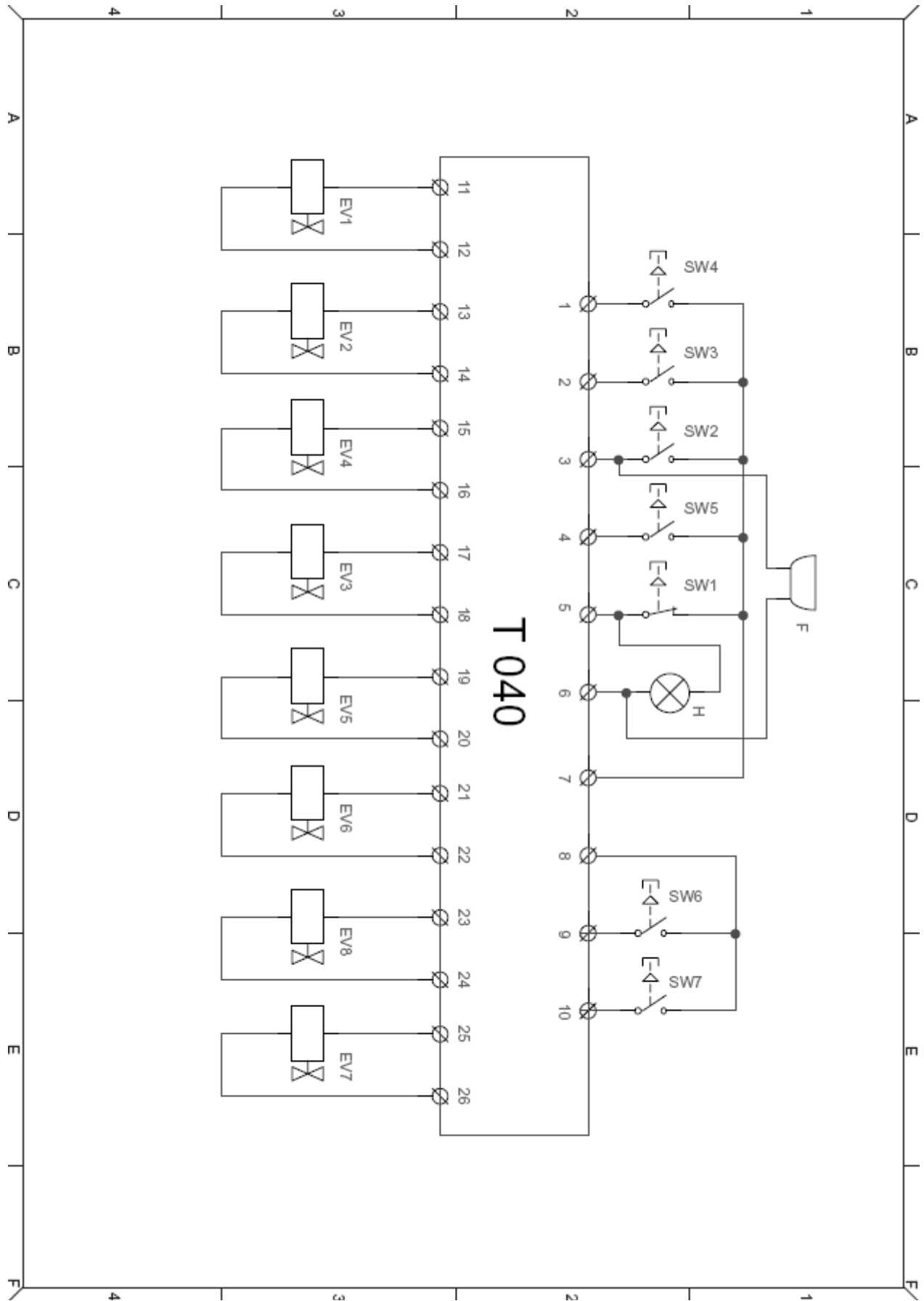

Figure 10l – ELECTRIC WIRING – terminals connections

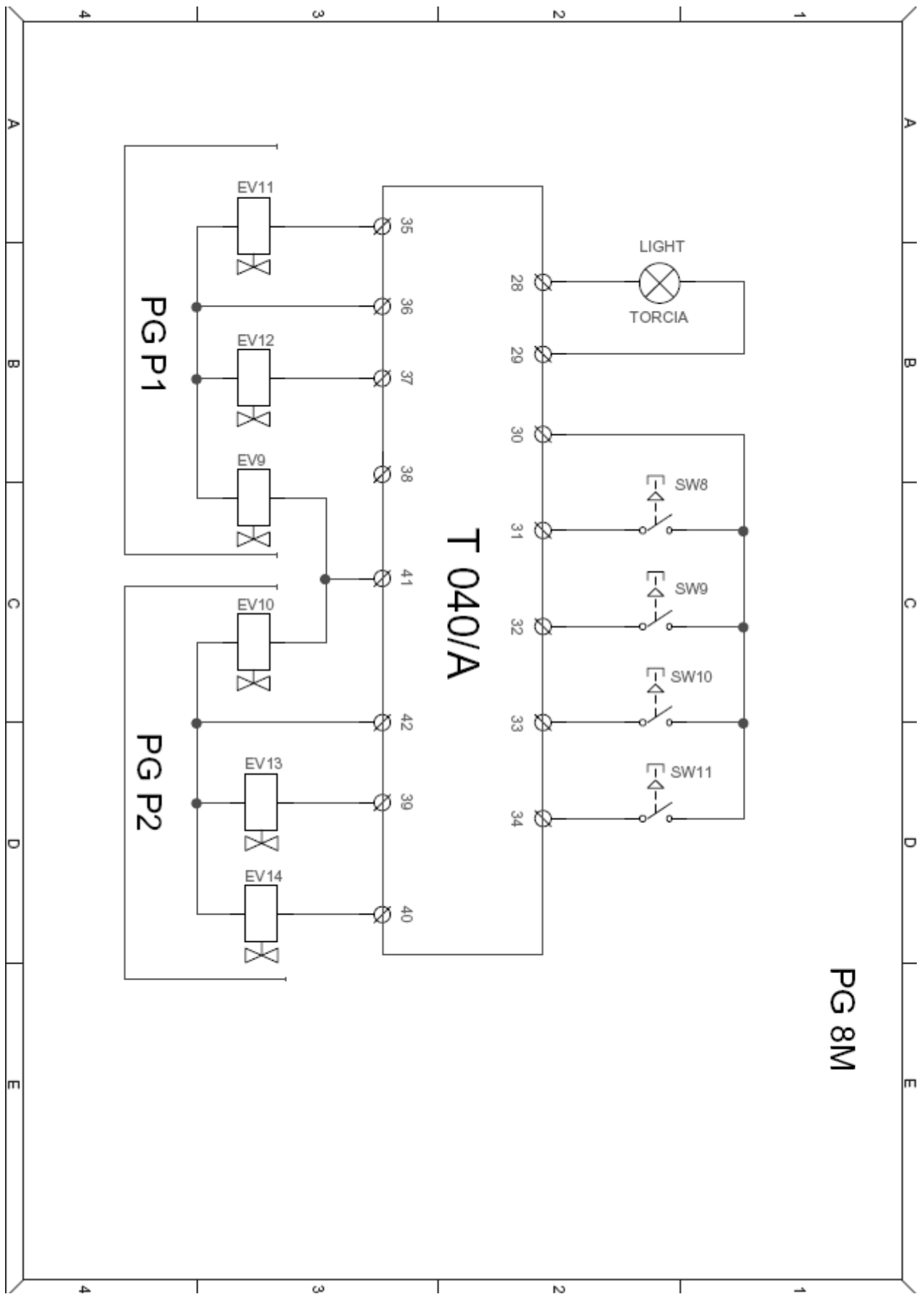
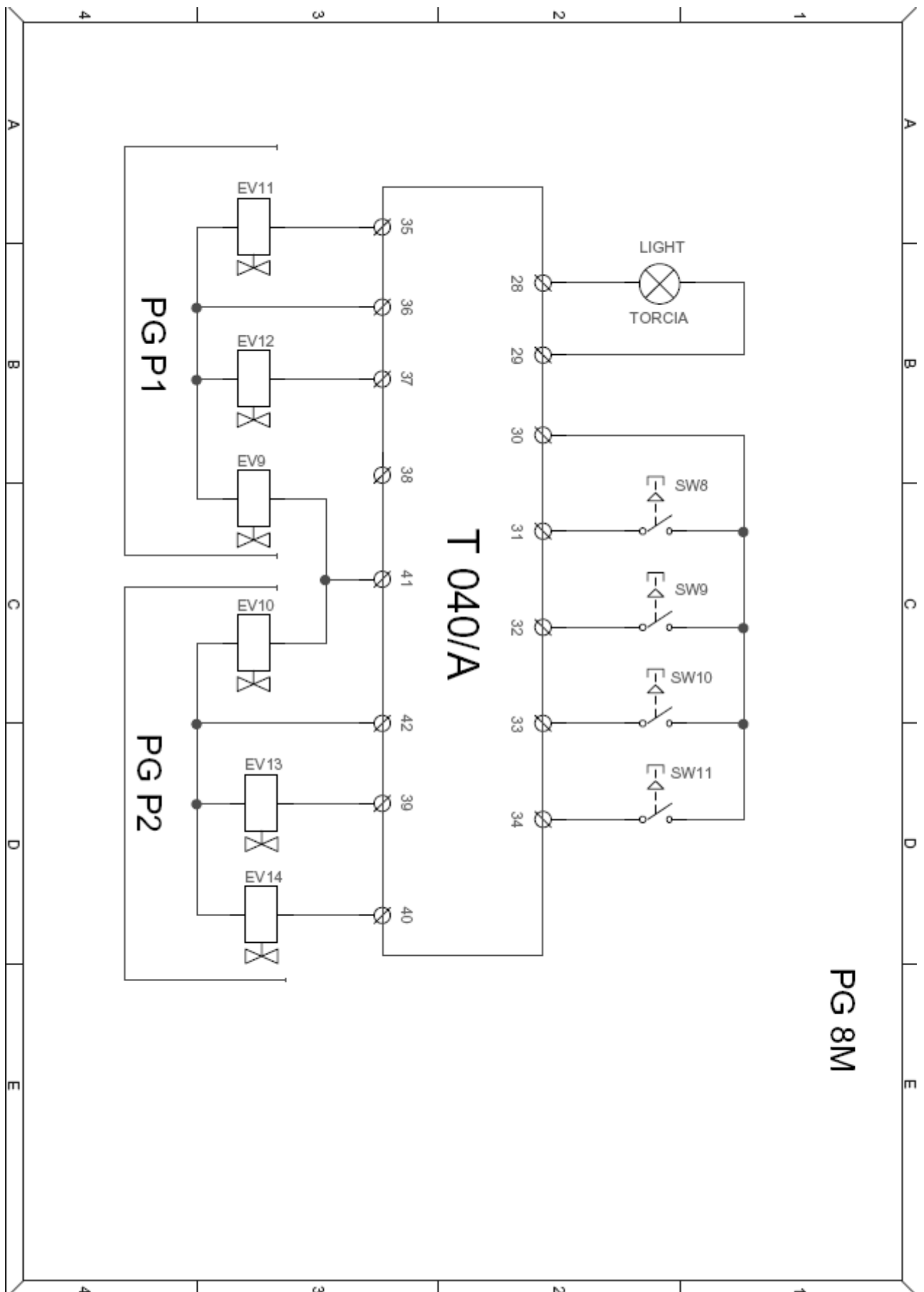

Figure 10m – ELECTRIC WIRING – terminals connections



SW1	Emergency button	EV13	PG P2 front-back movement sol. valve
SW2	Final lowering button	EV14	PG P2 SX-DX movement solen. valve
SW3	Down button	K-L1	Auxiliary lift selector
SW4	Up button	K-L2	Photocell
SW5	Lift- Aux. lift – play detector selector	K-L3	Top limit switch
SW6	1st working position button	K-L4	Leveling P1/P2
SW7	2nd working position button	K-L5	Lowering timer
SW8	Play detector movement button	K-L6	Final lowering timer
SW9	Play detector movement button	K-L7	UP push button
SW10	Play detector movement button	K-L8	DOWN push button
SW11	Play detector movement button	K-L9	Final Lowering push button
IG	Main switch	K-L10	Air timer
PDI	Rectifier	K-L11	Auxilairy relay
CM	Motor contactor	K-L12	Exclusion push button
F	Beeper	K-L13	Bottom limit switch
H	Pilot lamp	L28	Platform
M3	Three phases motor	L29	PCB energized
a	Platform maximum height limit switch	L30	Platform air solenoid valve
b	Photocell	L31	Platform leveling solenoid valve
c	Platform minimum height limit switch	L32	Platform switching solenoid valve
d	Platform P1 leveling limit switch	L33	Platform lowering solenoid valve
e	Platform P3 leveling limit switch	L34	Auxiliary lift air solenoid valve
f	1 st working position limit switch	L35	Auxiliary lift switching solenoid valve
g	2 nd working position limit switch	L36	Auxiliary lift leveling solenoid valve
h	Auxiliary lift P2 leveling limit switch	L37	Auxiliary lift lowering solenoid valve
i	Auxiliary lift max height limit switch	K-L27	Play detector switch (T040 A)
l	Auxiliary lift min height limit switch	K-L28	Play detector record (T040 A)
m	Auxiliary lift P1 leveling limit switch	K-L29	Play detector timer (T040 A)
EV1	Air solenoid valve platform	K-L22	Working positions stop (T040 B)
EV2	Platform leveling solenoid valve	K-L23	Working positions stop timer (T040 B)
EV3	Platform lowering solenoid valve	K-L24	Working position record (T040 B)
EV4	Platform switching solenoid valve	K-L25	Working position auxiliary (T040 B)
EV5	Air solenoid valve for auxiliary lift	K-L26	Timer for working position. (T040 B)
EV6	Auxiliary lift switching solenoid valve	K-L14	Aux. lift P1 leveling timer (T040 C)
EV7	Auxiliary lift lowering solenoid valve	K-L15	Aux. lift Leveling timer (T040 C)
EV8	Auxiliary lift leveling solenoid valve	K-L16	Aux. lift raising timer (T040 C)
EV9	PG P1 switching solenoid valve	K-L17	Aux. lift P2 leveling limit switch (T040 C)
EV10	PG P2 switching solenoid valve	K-L18	Aux. lift top limit switch (T040 C)
EV11	PG P1 front-back movement solenoid valve	K-L19	Aux. lift bottom limit switch (T040 C)
EV12	PG P1 SX-DX movement solenoid valve		

Legend :

WP	Working positions	K	Relay
LT	Auxiliary lift	L	Led
PG	Play detector		

Figure 11 – Sensors connection

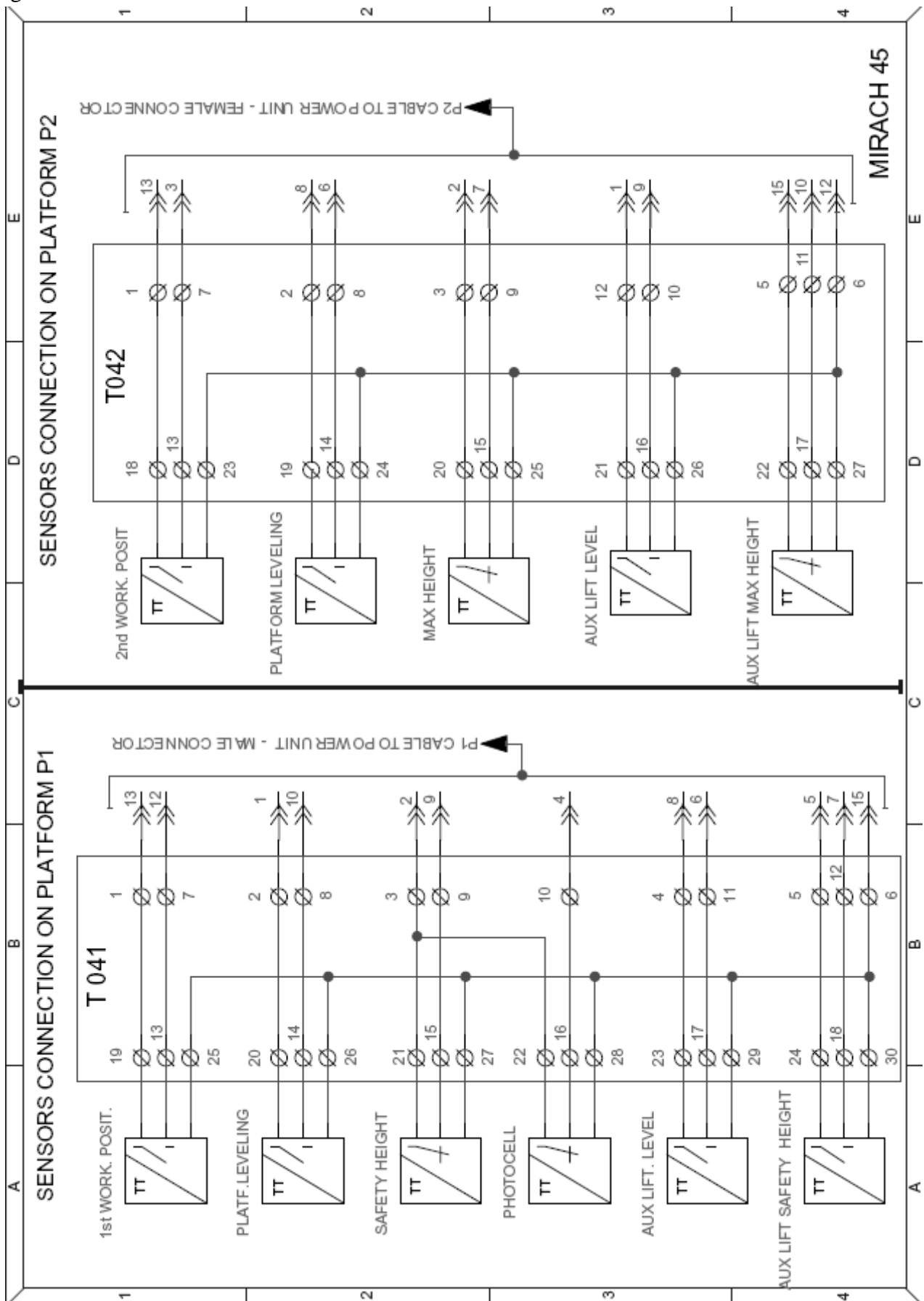

All models are equipped with PCB T040 (see. Layout fig.12) on which different card are plugged in according to different model as shown in following table::

Model	T040	T040A	T040B	T040C
N	X			
AT	X		X	
LT	X			X
ATLT	X		X	X
Play detector		X		

Figure 12 – Layout PCB T040

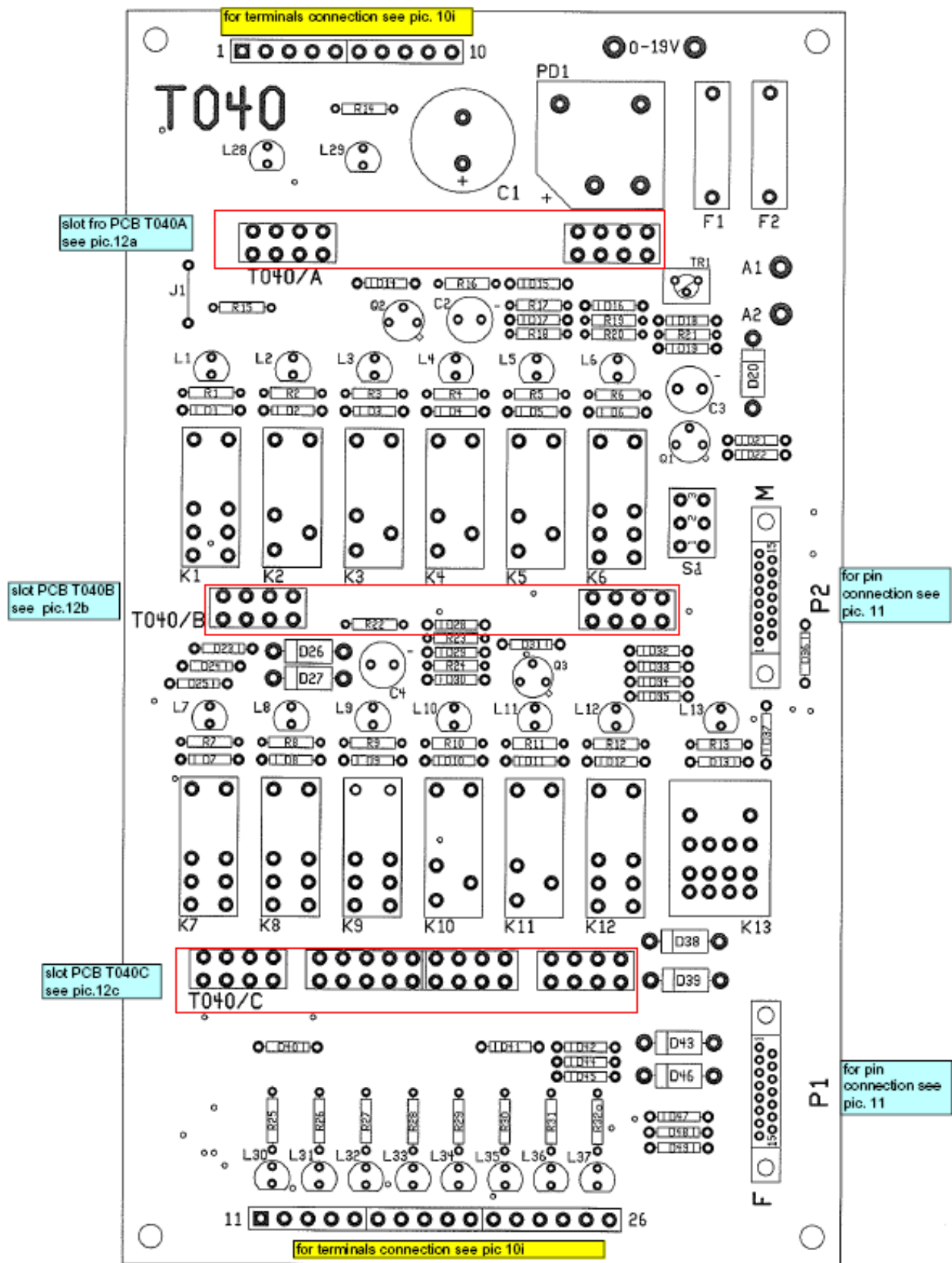

Figure 12a – Layout PCB T040A

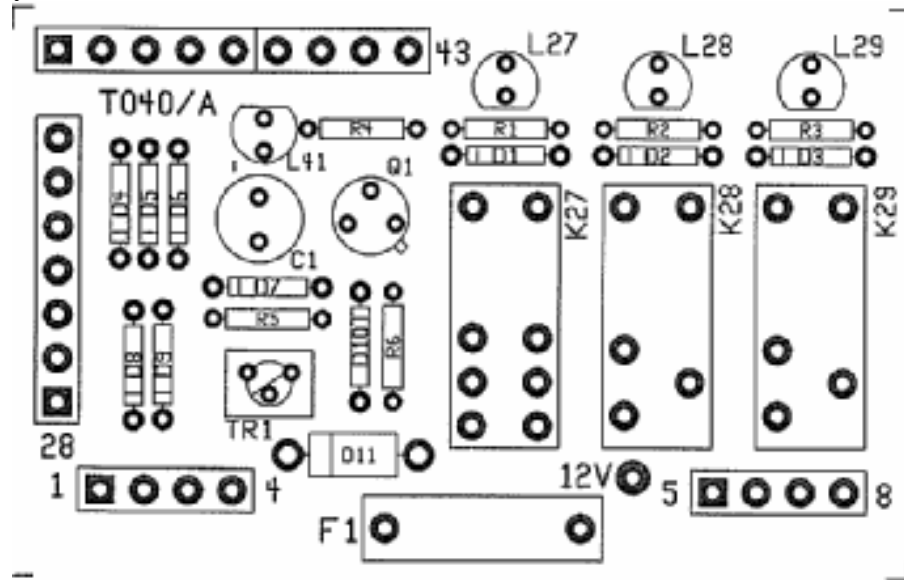

Figure 12b – Layout PCB T040B

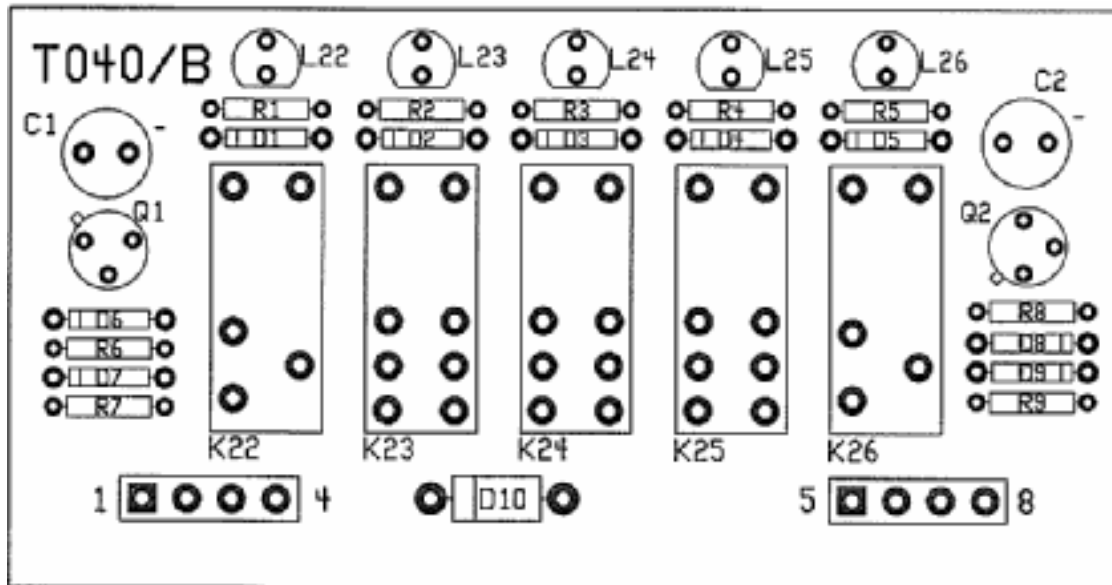
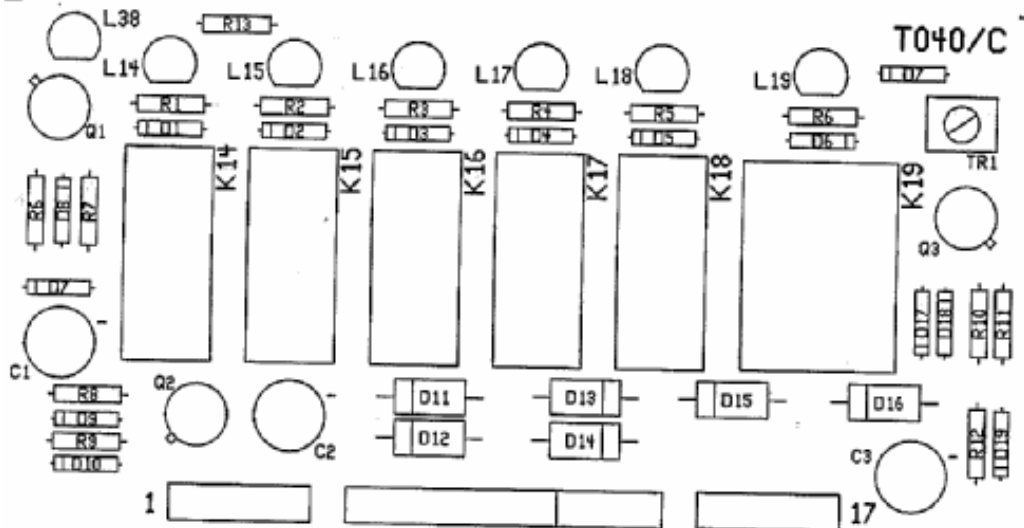

Figure 12c – Layout PCB T040C



5.7 HYDRAULIC PLAY-DETECTOR

All models can be equipped with two or eight movements hydraulic play-detector. This accessory are used for the control of the mechanical parts of the vehicle related to the directional organs (suspensions and relative axels).

The devices (two for each lift) are composed of :

- hydraulic play-detector (1) fixed at the runway end;
- drive-on ramp (2) caught at the play-detector;
- stabilizer (3) runways transversal fastening;
- portable lamp (4) with push button switches for directional movements control

Figure 13 – HYDRAULIC PLAY DETECTOR

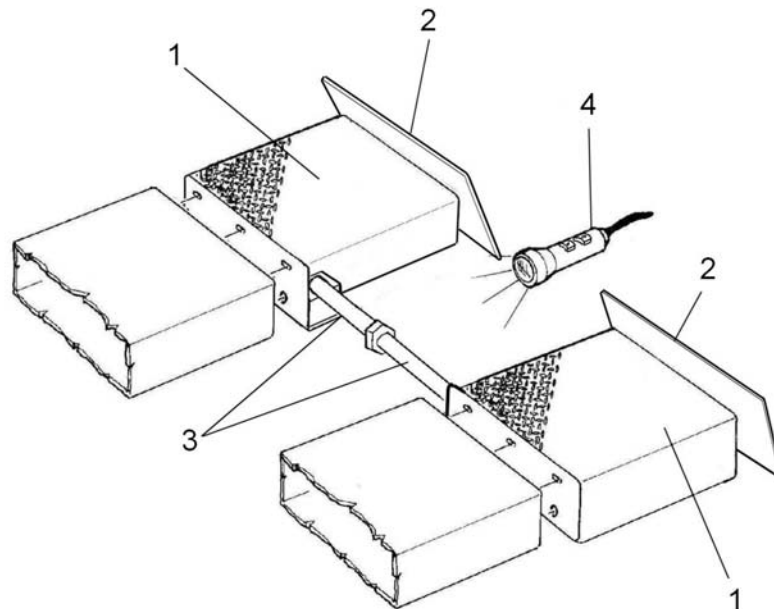

Note : for lift with 2 movements play detectors, an auxiliary hydraulic block is installed on main block.(see Figure 14)

Lifts with 8 movements play detectors the hydraulic block is installed into the play detector frame (see Figure 15) , 1 for each platform.

5.7 PLAY DETECTOR HYDRAULIC UNIT

The hydraulic unit of two movements play detector, has a solenoid valve for the movement play detector P1 (1), a solenoid valve for the movement play detector P2 (2) and a solenoid valve for release P1 and P2 (3).

Figure 14 – 2 MOVEMENTS PLAY DETECTOR HYDRAULIC UNIT

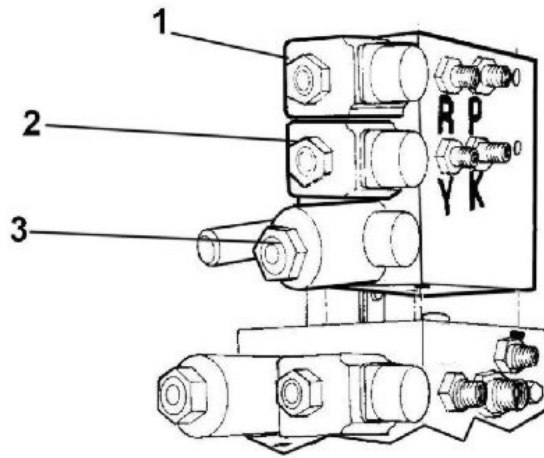
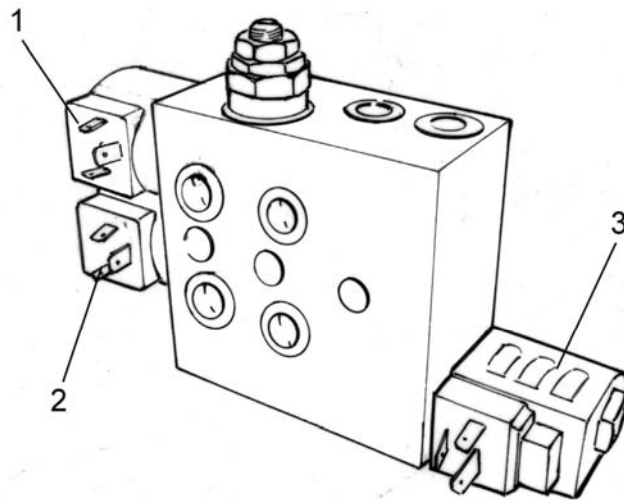



Figure 15 - 8 MOVEMENTS PLAY DETECTOR HYDRAULIC UNIT

The hydraulic unit of eight movements play-detector has a solenoid valve for the left/right movement upper plate (1), a solenoid valve for the front/rear movement lower plate (2) and one solenoid valve for release upper and lower plates



6 CHAPTER 6 - SAFETY

Read this chapter carefully and completely because it contains important information for the safety of the operator and the person in charge of maintenance

	<p>the lift has been designed and built for lifting vehicles and making them stand above ground level in a closed area. any other use is forbidden, including the following operations:</p> <ul style="list-style-type: none">washing of vehicles whilst on the liftpeople lifting or scaffoldingpressingloading of vehicle whilst on the lift <p>the manufacturer is not liable for possible damage to people, vehicles or objects resulting from an improper or unauthorized use of the lift.</p>
---	--

For operator and people safety, the safety area shown in picture 16 **Fehler! Verweisquelle konnte nicht gefunden werden.** must be vacated during lifting and lowering. The lift must be operated only from the operator's desk.

Operator's presence under the vehicle, during working, is only permitted when the vehicle is lifted and platforms are not running

	<p>Never use the lift when safety devices are off-line. people, the lift and the vehicles lifted and personnel can be seriously damaged if these instructions are not followed.</p>
---	--

Figure 16 – SAFETY AEREA

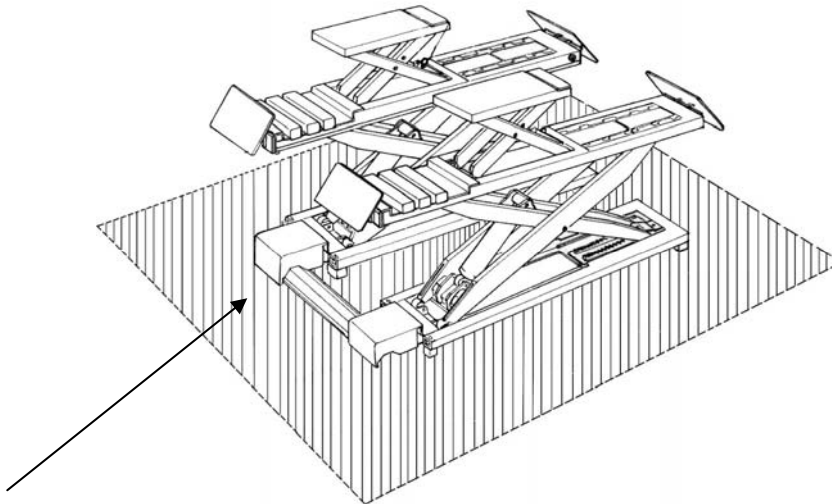

SAFETY AREA (min. 1 metre)

6.1 GENERAL WARNINGS

The operator and the person in charge of maintenance must follow accident-prevention laws and rules in force in the country where the lift is installed.

They must also carry out the following :

- neither remove nor disconnect hydraulic, electric or other safety devices;
- carefully follow the safety notices applied on the machine and included in the manual;

- observe the safety area during lifting;
- be sure the engine of the vehicle is switched off, the gear engaged and the parking brake put on;
- be sure only authorized vehicles are lifted without exceeding the maximum lifting capacity;
- verify that no one is on the platforms during lifting or standing.

6.2 RISKS DURING VEHICLE LIFTING

To avoid overloading and possible breaking, the following safety devices have been used:

- a maximum pressure valve placed inside the hydraulic unit to prevent excessive weight being lifted;
- a special design for the hydraulic system, in case of pipeline failure, to prevent sudden lift lowering.

6.3 RISKS FOR PEOPLE

Risks the personnel could run, due to an improper use of the lift, are described in this section.

6.4 PERSONNEL CRUSHING RISKS

During lowering of runways and vehicles, personnel must not be within the area covered by the lowering trajectory. The operator must be sure no one is in danger before operating the lift.



Fig. 17a



Fig. 17b

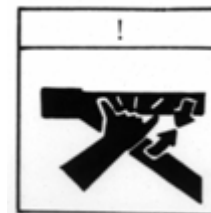

Fig. 17c

6.5 BUMPING RISKS

When the lift is stopped at a relatively low height for working, the risk of bumping against or into projecting parts occurs



Fig. 18

6.6 RISK OF THE VEHICLE FALLING FROM THE LIFT

Vehicle falling from the lift can be caused when the vehicle is improperly placed on the platforms, and when its dimensions are incompatible with the lift or by excessive movement of the vehicle. In this case, keep away from the immediate working area.

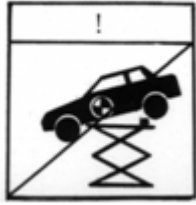

Fig. 19a



Fig. 19b

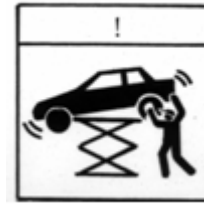

Fig. 19c

6.7 SLIPPING RISKS

The risk of slipping can be caused by oil or dirt on the floor near the lift.



Fig. 20



Keep the area under and around the lift clean. Remove all oil spills.

6.8 ELECTROCUTION RISKS

Avoid use of water, steam, solvent, varnish jets in the lift area where electric cables are placed and, in particular, next to the electric panel.

6.9 RISKS RESULTING FROM IMPROPER LIGHTING

Make sure all areas next to the lift are well and uniformly lit, according to local regulations.

6.10 RISKS OF BREAKING COMPONENTS DURING OPERATION

Materials and procedures, suitable for the designed parameters of the lift, have been used by the manufacturer to build a safe and reliable product. Operate the lift only for the use it has been designed for and follow the maintenance schedule shown in the chapter “Maintenance”.



Fig. 21

6.11 RISKS FOR UNAUTHORISED USES

The presence of unauthorized persons next to the lift and on the platforms is strictly forbidden during lifting as well as when the vehicle has been already lifted



Fig. 22



ANY USE OF THE LIFT OTHER THAN HEREIN SPECIFIED CAN CAUSE SERIOUS ACCIDENTS TO PEOPLE IN CLOSE PROXIMITY TO THE LIFT

7 CHAPTER 7 - INSTALLATION



only skilled technicians, appointed by the manufacturer, or by authorised dealers, must be allowed to carry out installation. serious damage to people and to the lift can be caused if installations are made by unskilled personell.



Before carrying out any operations, remember to insert the safety piece of wood between the lower booms and the base frame (Rif. fig. 23).



Before compressed air connection, fill in the hydraulic cylinders with oil.

Figure 23 – SAFETY BLOCK



PRELIMINARY OPERATIONS

7.1 CHECKING FOR ROOM SUITABILITY

The lift has been designed to be used in covered and sheltered places.

The place of installation must not be next to washing areas, painting workbenches, solvent or varnish deposits. The installation near to rooms, where a dangerous situation of explosion can occur, is strictly forbidden. The relevant standards of the local Health and Safety at Work regulations, for instance, with respect to minimum distance to wall or other equipment, escapes and the like, must be observed.

7.2 LIGHTING

Lighting must be carried out according to the effective regulations of the place of installation. All areas next to the lift must be well and uniformly lit.

7.3 INSTALLATION SURFACE OR INSTALLATION HOLE

The lift must be placed on a 425 concrete floor with FEB 215 K reinforcement, 16cm thick at least, and in conformity with local regulations.

If a floor covering with the above mentioned requirements is not available, a foundation plate is needed or, some fixing points should be used, for fixing areas at least, having sufficient size and thickness (made of concrete of the same quality, as shown).

The surface where the lift has to be installed must be even and leveled in all directions. An inclination not higher than 2 cm in drive-on lift direction and 1 cm cross-wise can be balanced with leveling wedges.

If an installation is made in a hole, the real side of the hole must be verified (as per drawing sent at the order). For installation on raised surface, the compliance with the maximum carrying capacity of the surface is recommended.

Floor fixing is the same both in on-floor and in-ground installations

7.4 RUNWAY ASSEMBLY AND CONTROL DESK POSITIONING



Unauthorized persons are not allowed to enter during assembly.

Transport platforms to the installation site by using hoisting means with load capacity of 1500 kg at least

To prevent the platform from dropping during transport, it should be lifted according to its centre of gravity.

Always raise platforms by holding them on the underside of the base frames.

Position the base frames on the foundation according to the drive-on direction of the lift. (Align platforms parallel to each other and in the drive-on direction of the lift).

Lift platforms with auxiliary equipment by using strong ropes, bands and chains and insert the safety blocks supplied with the lift.

Place the control desk in the required position.

7.5 HYDRAULIC SYSTEM CONNECTION

- Connect hydraulic hoses to the fittings placed on the fixed platforms referring to the letters shown on them.
- Tighten thoroughly.
- Connect hydraulic hoses to the fittings placed on the hydraulic unit referring to the letters shown on them.
- Tighten thoroughly.

Figure 24a – HYDRAULIC PIPES CONNECTION
MODEL “N” AND “AT”

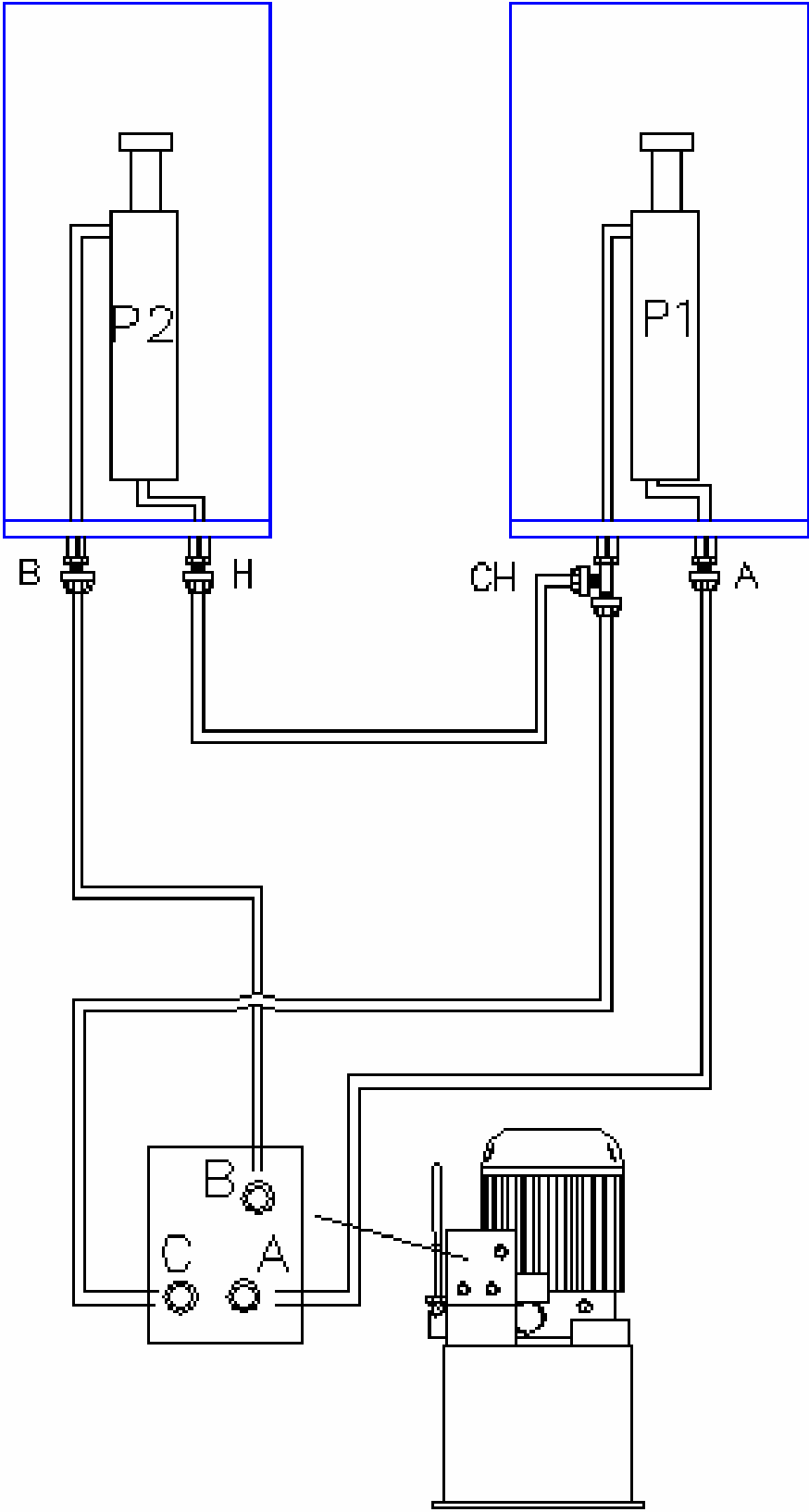

Figure 24b - HYDRAULIC PIPES CONNECTION MODELS "LT" AND "LTAT"

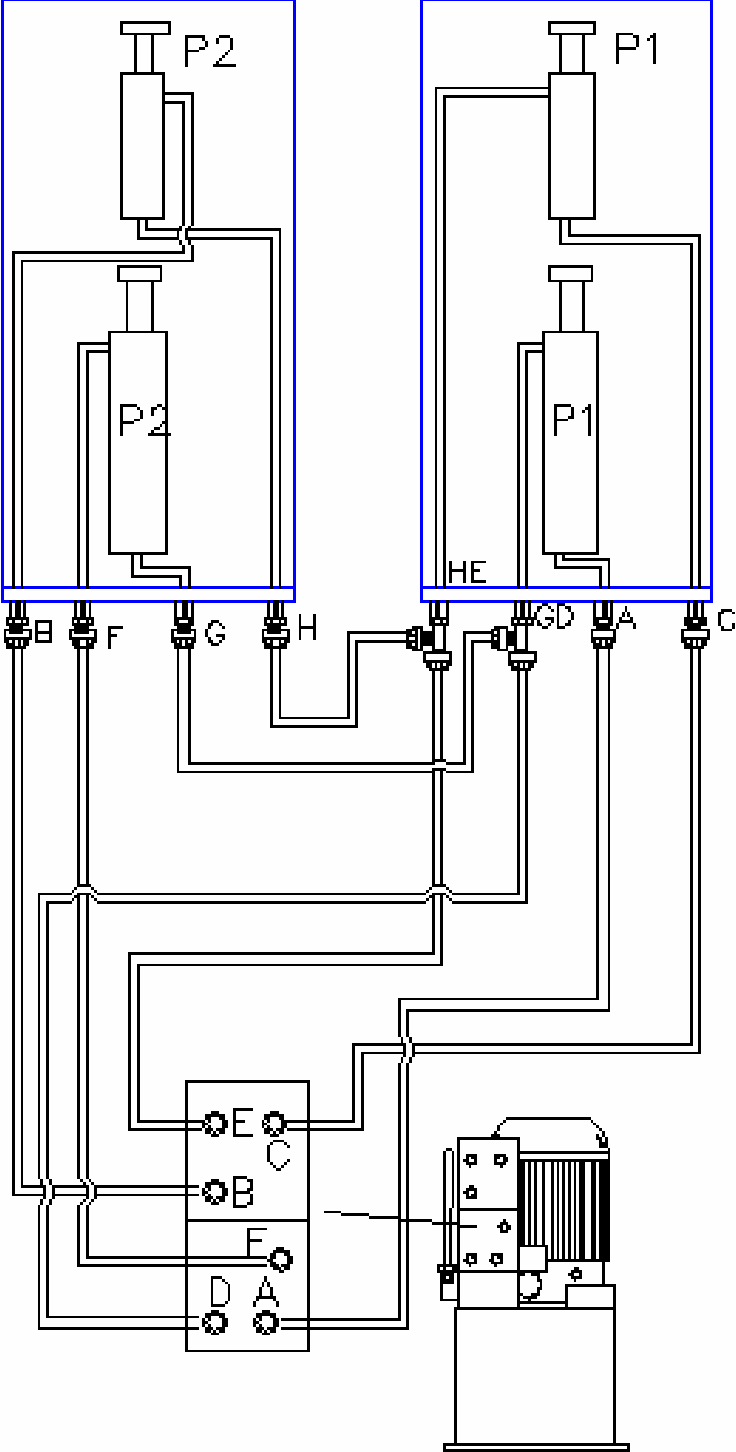

Figure 24c – HYDRAULIC PIPES CONNECTION
MODEL “N” AND “AT” + PD8M

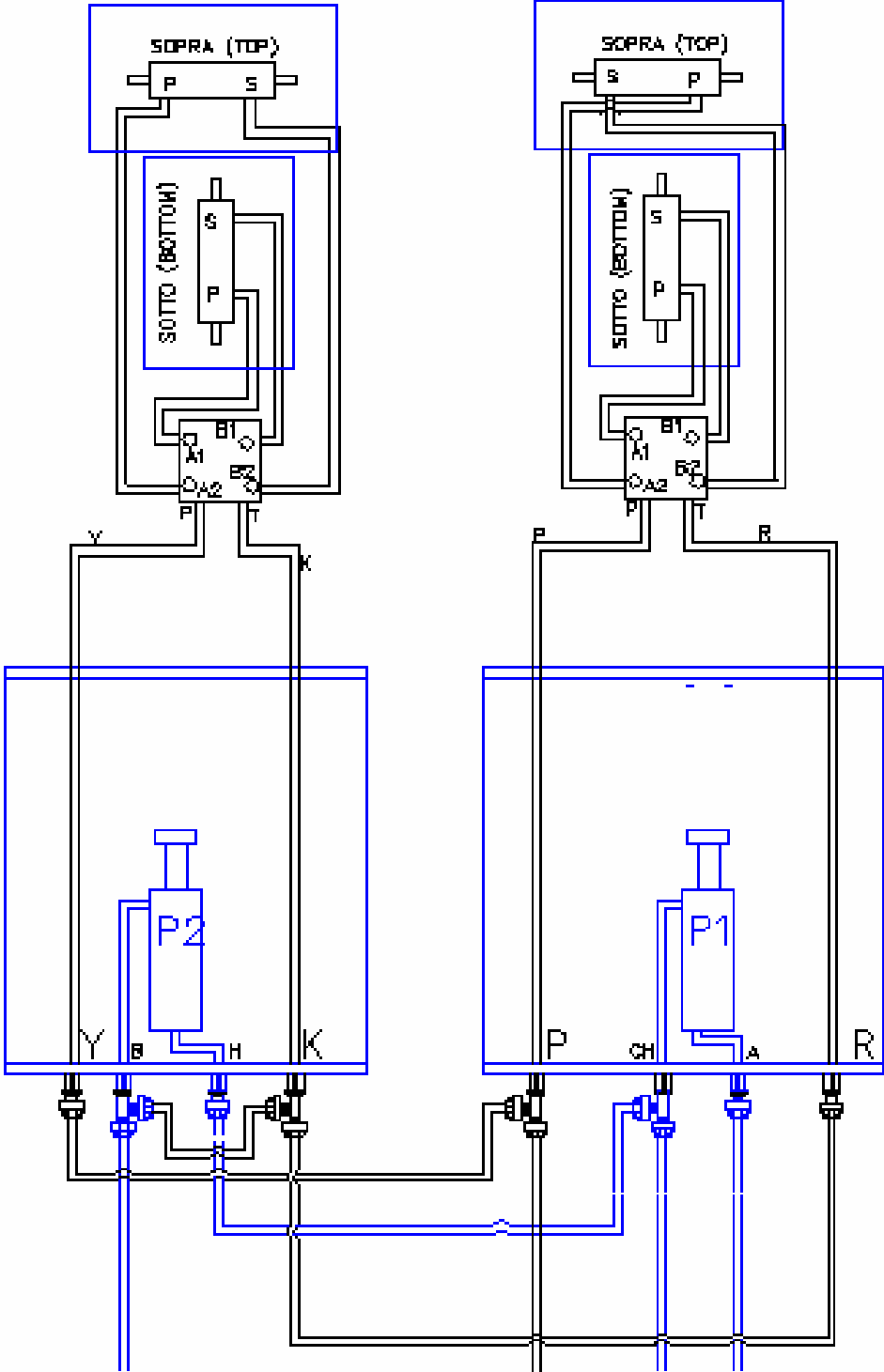
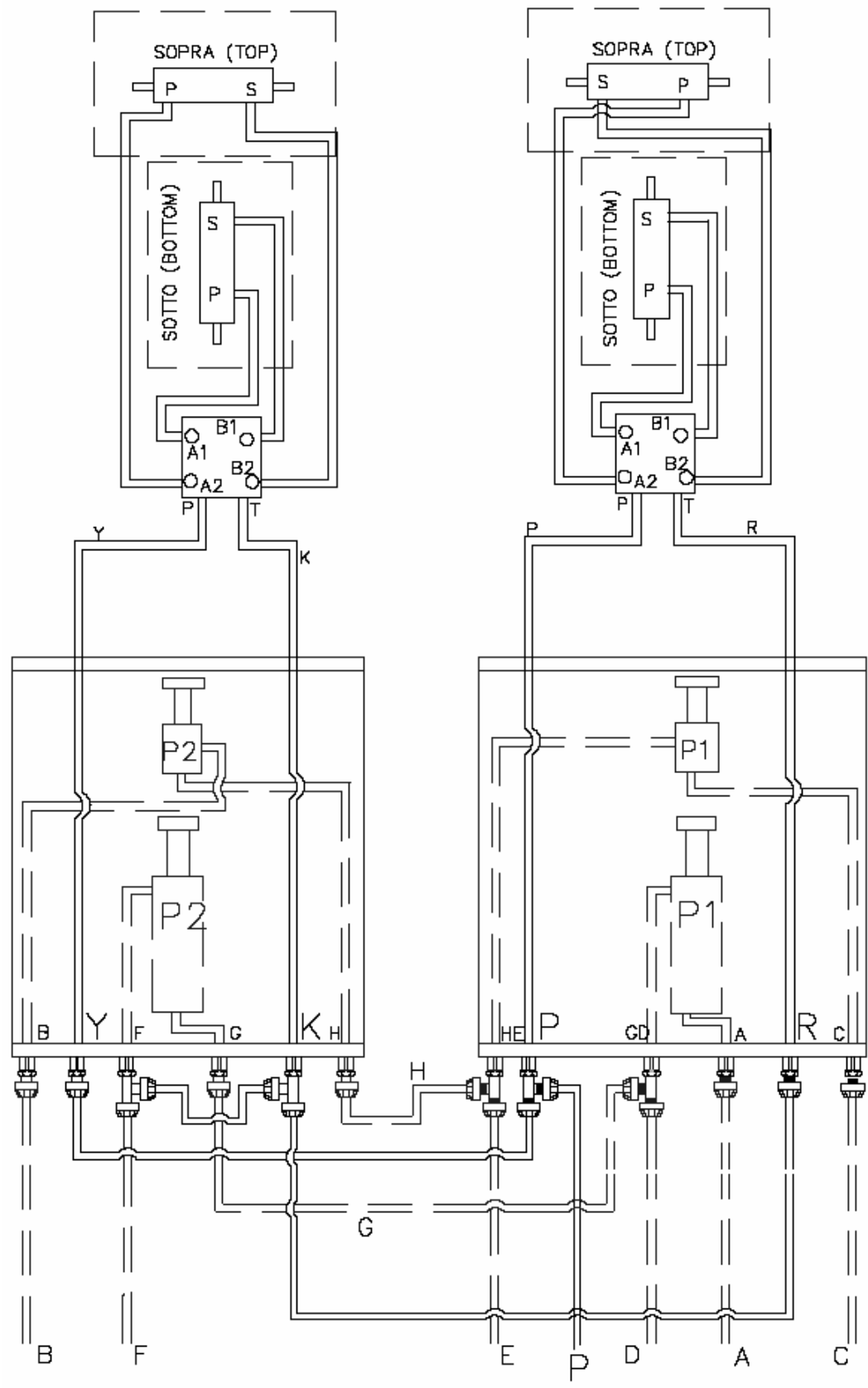

Figure 24d - HYDRAULIC PIPES CONNECTION MODELS "LT" AND "LTAT" + PD8M



7.6 ELECTRICAL SYSTEM CONNECTION

- Connect the runways cables on the electric main board connectors;
- Connect the feeding cable inside power unit;
- Ensure the grounding or earth is connected.

Figure 25 - ELECTRICAL SYSTEM CONNECTION

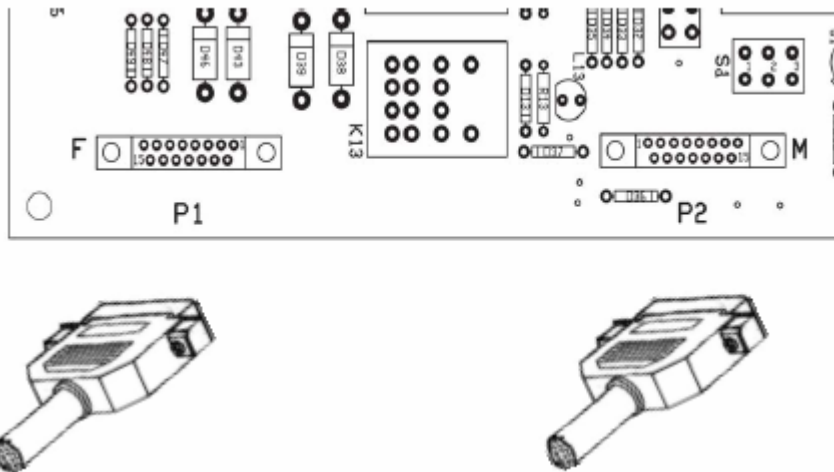

7.7 CONNECTION OF THE PNEUMATIC LINES



Warning: The connection of the lift to the general pneumatic system must be carried out only when the platforms have been raised to the top position to prevent mechanical safeties from disengaging unintentionally .

The disengagement of the gear racks and the locking of the slip plates are carried out pneumatically (only for models AT e LTAT).

The pneumatic supply at site (to which the pneumatic system of the lift is connected) must be equipped with a servicing unit composed of water separator, oiler and pressure reducer. These devices can be supplied by the manufacturer on request

For the connection of the pneumatic lines proceed as follow:

- Raise the lift to the final top position
- Connect the pneumatic lines pre-assembled on the runways in the control desk according to the color marking
- Connect the pneumatic system of the lift to the pneumatic supply at site
- Check the pneumatic control operations for proper performance

Figure 26 –PNEUMATIC PIPES CONNECTIONS

- 1 Platforms mechanical safeties disengagement
- 2 Slipping plates locking (AT e LTAT)
- 3 Auxiliary lift mechanical safety disengagement (models LT and LTAT)
- L1 White pneumatic pipe (Platforms mechanical safeties)
- L2 Blue pneumatic pipe (slipping plates)
- L3 Red pneumatic pipe (auxiliary lift mechanical safeties))

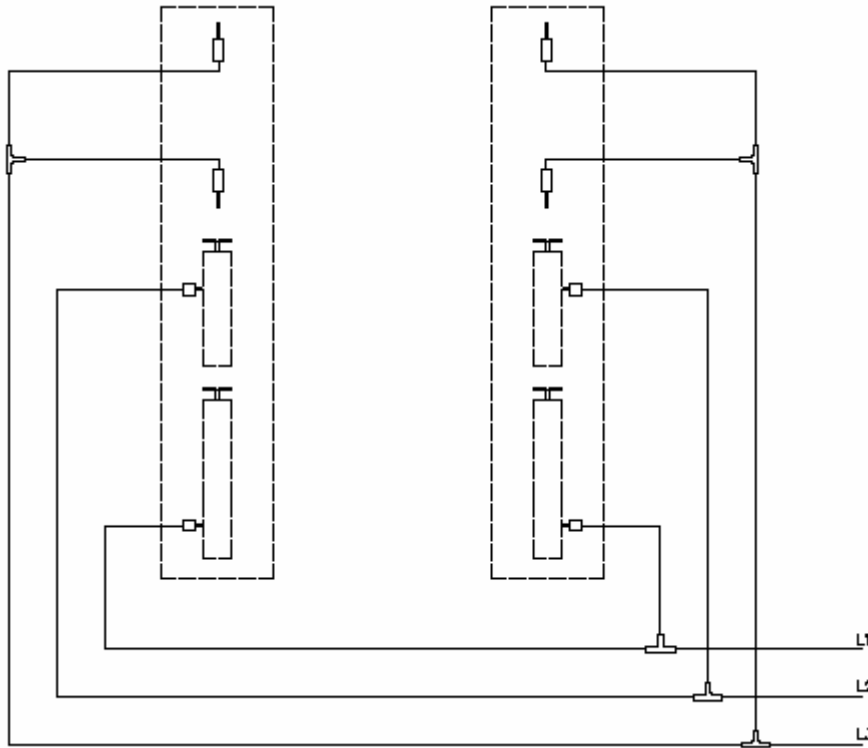

7.8 START UP

- Be sure the working area is free from people and objects;
- Be sure the electrical system feeding voltage is equal to that of the control box supplied with the lift (230 V or 400 V);
- Verify that the control desk is powered;
- Pour oil in the tank :
 - a. about 20 liters a little at a time (for models N and AT);
 - b. about 30 liters a little at a time (for models LT and LTAT);
- Supply power to the lift turning the main switch on;
- Verify that the motor direction of rotation is that shown on the label; if not interchange the phases;
- Press the override button (15) then press the UP button (7). so the platform P1 will reach the top position and, at this point only, the platform P2 will reach in turn the same height.;
- Hold the buttons pressed for further few seconds until air in the cylinder P2 comes out;

NOTE: IN CASE OF PLATFORM DIFFERENCE IN HEIGHT, REPEAT THE OPERATION

- Blow into the main feeding circuit (see par. 7.7);
- Disengage manual securities (see fig. 20);

- Press the DOWN button (8) until the platforms reach the security height (400 mm);
- i In case of platform difference in height, the photocell is operated preventing lift from lowering up to the safety height: in this case press simultaneously the override button (15) and the DOWN button (8);
- press final lowering button (5).

FOR MODELS “LT” AND “LTAT”:

- Turn the selector (11) in auxiliary lift position;
- Push the UP (7) to raise the lift-tables;

After stopping the lift-table platform P2, proceed with the bleeding as described below:

- Push simultaneously the override (15) and UP button (7) until the lift-tables reaches the maximum height ;
- Push, for a few seconds, both buttons until the P2 cylinder hole return hose is bled;
- Push the DOWN (8) button for lowering the platforms to the safety height (130 mm);
- press final lowering button (5)

NOTE: PLATFORMS LOWERS WITHOUT MOTOR SUPPORT BECAUSE IT STARTS AFTER DEACTIVATING THE UP LIMIT SWITCH ON P2 LIFT-TABLE

7.9 CHECKS AND INSPECTIONS

7.9.1 MECHANICAL CHECKS

- Platform leveling and alignment;
- Fix the lift to the ground with 8 anchor bolts (min. recommended size $\phi = 16 \text{ mm tighter}$), bolts, connectors and connections.
- Clean all parts of the equipment

7.9.2 ELECTRICAL CHECKS

- connections as per diagrams
- lift grounding (earthing)
- operation of the devices and limit switches

7.9.3 HYDRAULIC SYSTEM CHECK

- proper oil level in the tank
- no leakage and blow-by
- cylinder operation

7.10 SET UP AND ADJUSTMENTS

7.10.1 LOADLESS CHECK

Carry out two or three complete cycles of lowering and lifting and check:

- the lift for reaching its maximum height
- the max height limit switch for proper operation
- the lowering limit switch for proper operation

- leveling limit switches for proper operation (both the platforms should lower simultaneously)
- the horn /signaling light for proper operation during the final travel;

7.10.2 CHECK WITH LOAD

Repeat checks in section 7.10.1 with the vehicle loaded;

7.10.3 BOLTS AND NUTS CHECK

After carrying out the checks with a load, make a visual inspection of the equipment and check bolts and nuts for proper tightening

7.11 LIMIT SWITCHES ADJUSTMENTS



ONLY SKILLED PERSONNEL MUST BE ALLOWED TO CARRY OUT THIS OPERATION. AN IMPROPER ADJUSTMENT OF THE LIMIT SWITCHES COULD CAUSE DAMAGE TO THE LIFT, OBJECTS AND PEOPLE

- Check the bolts for proper tightening that assures the limit switches;
- Check the wheel that assure the cams to the arms,
- Check the correct position of each limit switches.

7.11.1 ADJUSTMENT OF MAXIMUM WORKING HEIGHT LIMIT SWITCH

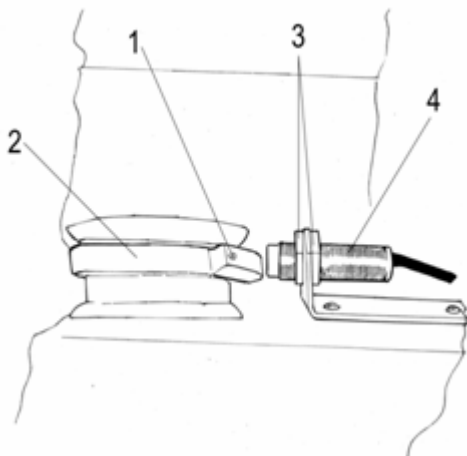

Fig. 27

Press UP button (7) and verify that platforms reach the height of 1850 mm
If this has not happened, adjust the limit switch as follows:

- By pressing Up button (7), raise the lift to a height of 1850 mm; if the limit switch acts before such height, push the Up button (7), and the exclusion button (15) simultaneously.
- Loosen dowels (1) which lock the cam (2) between the arms of platform P2
- Turn the cam (2) until the limit switch detects it
- Tighten the dowels (1) properly

In case the limit switch does not detect the cam, adjust it as follow:

- Loosen nuts (3) and move the sensor (4) towards the cam (2) at a distance of 1 to 3 mm.

Tighten nuts (3)

7.11.2 ADJUSTMENT OF SAFETY HEIGHT LIMIT SWITCH

Screen the photocell (if the lift is in hole, raise the lift up to an height of about 150 mm) by pressing UP button (7): the lift will raise and stop at the safety height (about 400 mm).

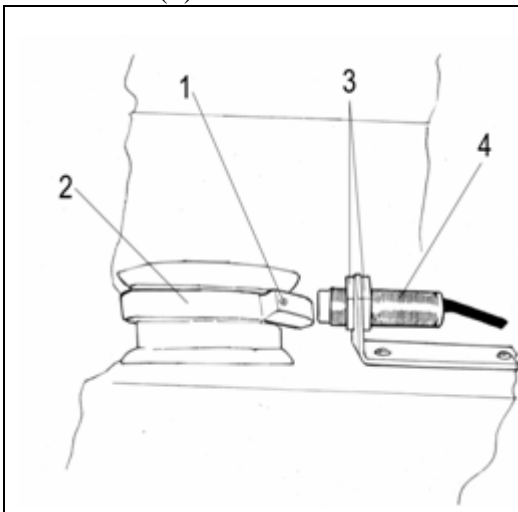

Fig. 28

If this has not happened, adjust the limit switch as follows:

- By pressing Up button (7), raise the lift to a height of 400 mm;
- Loosen dowels (1) which lock the cam (2) between the arms of platform P1;
- Turn the cam (2) until the limit switch detects it
- Tighten the dowels (1) properly

In case the limit switch does not detect the cam , adjust it as follow:

- Loosen nuts (3) and move the sensor (4) towards the cam (2) at a distance of 1 to 3 mm.
- Tighten nuts (3);



N.B. PLATFORMS CANNOT BE AUTOLEVELED IF THE SAFETY HEIGHT LIMIT SWITCH IS NOT PROPERLY ADJUSTED.

7.11.3 ADJUSTMENT OF PLATFORM AUTO-LEVELING LIMIT SWITCH

With the lift on the ground, press the safety UP button, and hold it pressed to verify , on th eprinted circuit board, the proper operation of relay K4, if the correspondent light is switched on the auto-leveling sensor of platform P2 works properly.

With the lift in lowest position ,press final lowering button, and check on printed circuit board the relay K4 works properly. f the correspondent led is switched on the auto leveling sensor of platform P1 works properly

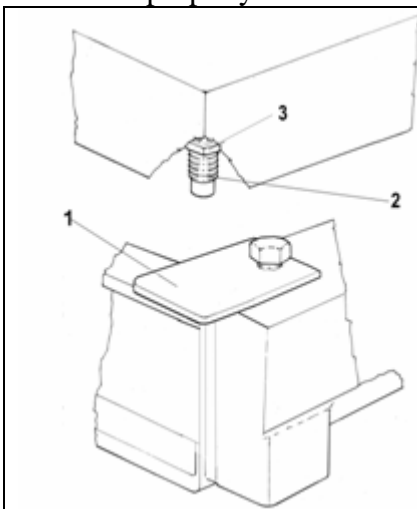
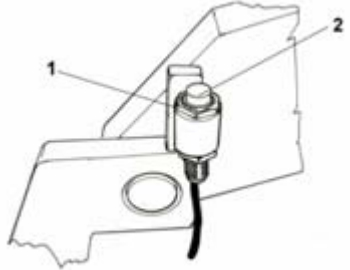

Fig. 29

If this has not happened, adjust the limit switch as follows:

- verify the steel sheet (1) orientation with the limit switch (3);
- loosen the nuts (3) of the proximity pick up (2) and adjust it at a distance between 1 and 3 mm from the lamination (1);
- tighten nuts (3).

7.11.4 CHECK AND ADJUSTMENT OF LIFT-TABLE LEVELLING LIMIT SWITCH (UP)

 <p style="text-align: center;">FIG. 30</p>	<p>With the lift-table operating, press UP button (7) and check if, on the printed circuit board L36 led lights up for a while.</p> <p>If this has not happened, adjust the limit switch (installed on platform P2) as follows:</p> <ul style="list-style-type: none"> • place the lift at the height of about 1500 mm; • lower completely the lift-table; • loosen nuts (1); • bring the sensor (2), placed on the lift platform P2, nearer the lift-table platform at a distance of 3 mm; • tighten nuts
---	---

7.11.5 CHECK AND ADJUSTMENT OF LIFT-TABLE LEVELLING LIMIT SWITCH (DOWN)

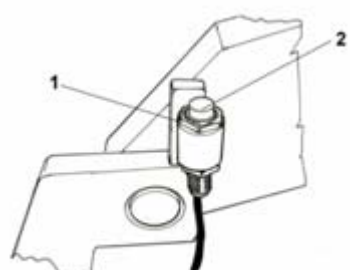
 <p style="text-align: center;">FIG. 31</p>	<p>With the lift-table operating, press the safety DOWN button (5) and check if, on the printed circuit board L35 e L37 led light up for a while. Once final position has been reached release final lowering button (5) and check if L36 led lights.</p> <p>If this has not happened, adjust the limit switch as follows:</p> <ul style="list-style-type: none"> • lower completely the lift-table; • loosen nuts (1); • bring sensor (2), installed on platform P1 of the lift, towards auxiliary lift platform, at a distance of 1-3 mm; • tighten nuts.
---	---

7.11.6 AUXILIARY LIFT SAFETY HEIGHT LIMIT SWITCH ADJUSTMENT (130MM)

With the lift-table operating, press Down button (8) and check the auxiliary lift stops at a height of 130 mm.

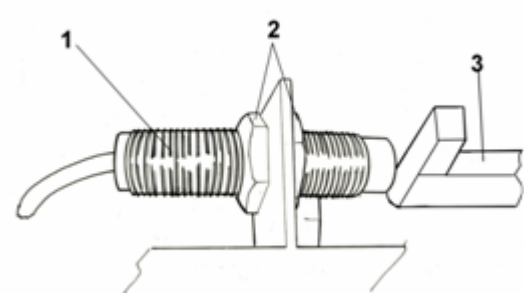
 <p style="text-align: center;">Fig.32</p>	<p>If this has not happened, adjust the limit switch (installed on platform P1) as follows :</p> <ul style="list-style-type: none"> • raise the lift table at a height of 130 mm from lift platform; • loosen dowels which fix the cam to the arm and turn it until the limit switch detects its presence; • tighten the dowels properly <p>if the limit switch does not detect the cam, adjust it as follows:</p> <ul style="list-style-type: none"> • loosen nuts (2) of sensor (1), installed on external arm of auxiliary lift P1, and
--	--

- move it towards the cam (3) at a distance of 1 to 3 mm;
- tighten the nuts properly

7.11.7 AUXILIARY LIFT MAX HEIGHT LIMIT SWITCH ADJUSTMENT (rif. Figure 29)

With the lift-table operating, press Up button (7) and check the lift stops at 450 mm height.

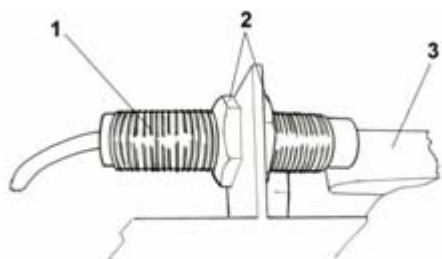

Fig.33

If this does not happen adjust the limit switch as follow (installed on platform P2) :

- With the lift-table operating, press Up button (7) and raise it at a height of 450 mm from lift platform; if the limit switch operates before such height, press the UP button (7) and the exclusion button (15) simultaneously.;
- loosen dowels which fix the cam to the arm and turn it until the limit switch detects its presence;
- tighten the dowels properly

if the limit switch does not detect the cam, adjust it as follow:

- loosen nuts (2) of sensor (1), installed on external arm of auxiliary lift P2, and move it towards the cam (3) at a distance of 1 to 3 mm;
- tighten the nuts properly

7.11.8 WORKING POSITION LIMIT SWITCH ADJUSTMENT

Le posizioni di lavoro vengono regolate dalla casa costruttrice ma possono essere cambiate a seconda delle necessità dell'utente nel campo tra l'altezza minima e massima

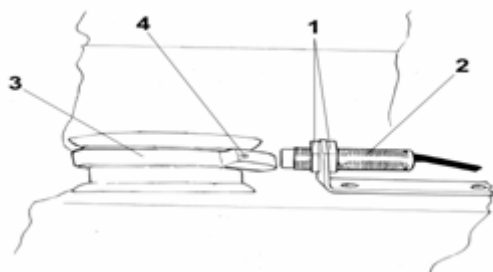

Fig.34

When working position buttons (13) and (14) are pressed, the platform reaches max height without stopping at any intermediate height, the limit switches must be adjusted as follow:

- raise the lift to 1st working position by pressing correspondent button.;
- loosen dowels (4) which fix the cam (3) to the arms of the platform P1 and turn cam (3) until the sensor detects it, and correspondent led on display switches on ;
- tighten dowels properly

if the limit switch does not detect the cam, adjust it as follow:

- loosen nuts (1) of sensor (2), and move it towards the cam (3) at a distance of 1 to 3 mm;
- tighten the nuts properly

Repeat the same operation to set 2nd working position limit switch

7.12 PLATFORM ADJUSTMENT

To adjust platforms properly, operate as follows :

- a) Raise the lift (without the vehicle) up to an height of about 1.5 metres and insert mechanical safeties;
- b) verify that both the platforms are leveled (horizontally) independently of the supporting floor morphology (by means of a water gauge or an air bubble) and, if necessary, adjust in the following way:
 - remove the fixing bolt (1);
 - adjust the adjusting screw (2) until the required conditions are obtained;
 - on the higher platform only, reinsert the fixing bolt (1) and tighten.
 - Using the same tool, level platforms among them by adjusting the supports, shown in the figure, that belong to the lower platform
 - Once the required conditions have been obtained, lean the other supports, reinsert the fixing bolt (1) and tighten.

Figure 35 – PLATFORMS ADJUSTMENT

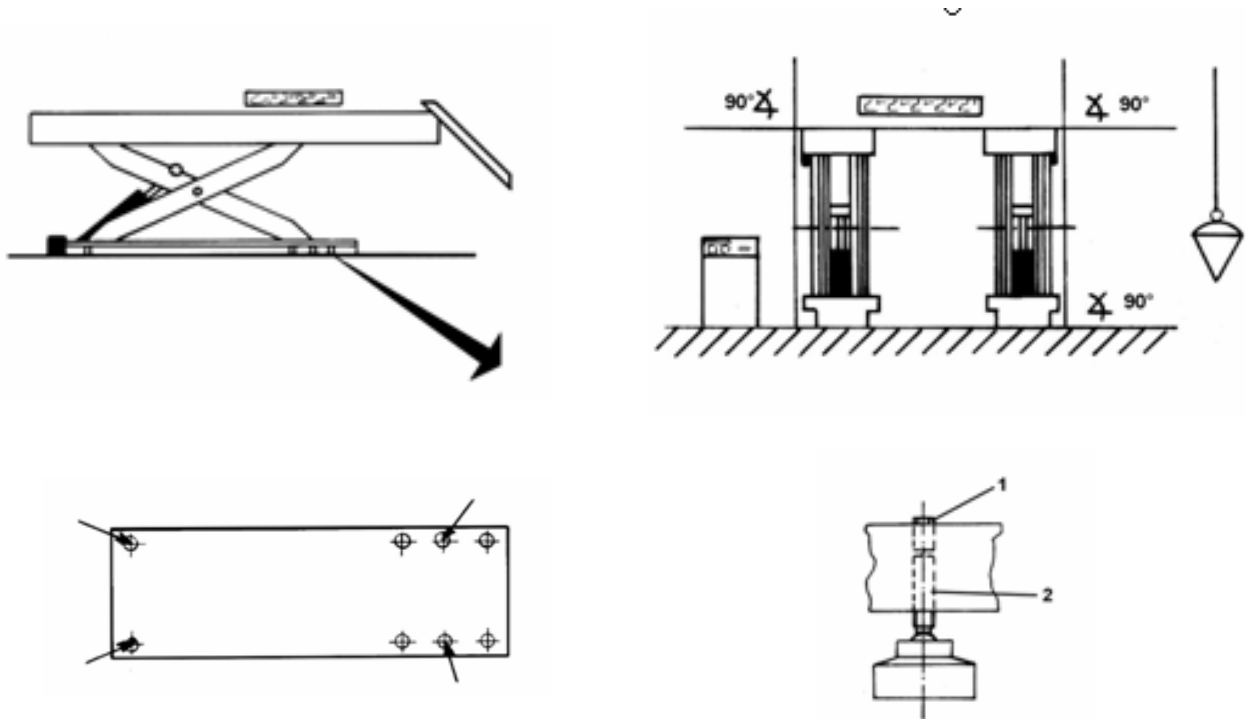

Verify the distance between the lift base and the bearing surface (floor or hole), after leveling the lift.



If this distance is too great, or not exactly the same on the ends, other fastening points to the bases, such as cement, chemical bi-component or an iron plate, have to be provided, in order to prevent the base from bending under the weight of the lift or the vehicle.

Figure 36 – LIFT LEVELING

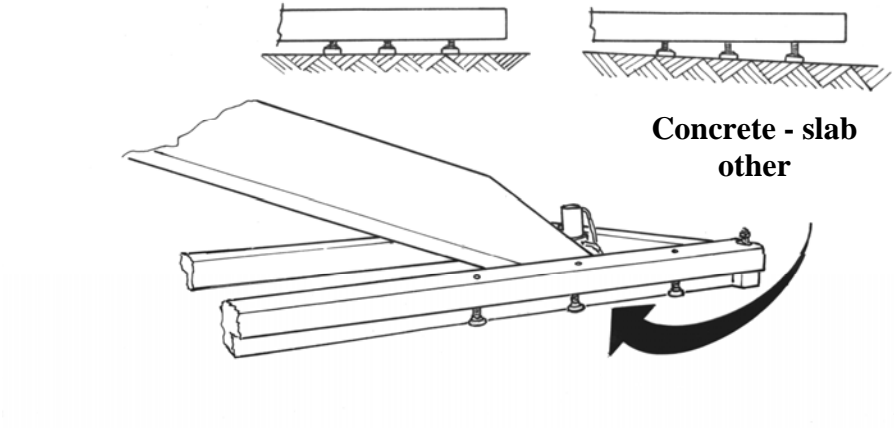

8 CHAPTER 8 - OPERATION AND USE

8.1 CONTROLS

Controls for operating the lift are:

GENERAL SWITCH (12)

Main switch has two positions:

- **0 Position:** the electric circuit is not powered; the switch can be padlocked to prevent the use of the lift.
- **1 Position:** the electric circuit is powered; the lift can be operated.

UP BUTTON (7)

- When pressed, motor and hydraulic circuit solenoid valve operate and the lift will be raised.

DOWN BUTTON (8)

- When pressed, the motor and the release hydraulic circuit solenoid valve are operated, the lift can be raised and mechanical safeties released. So, the motor is stopped, the lowering solenoid valve is operated and the lift can be lowered up to the safety height (400 mm from the ground)

FINAL LOWERING BUTTON (5)

- When pressed under the safety height limit switch, the horn and, after a few seconds, the hydraulic unit release solenoid valve, the air solenoid valve and the lowering solenoid valve are operated and the lift can make its final travel.
- When pressed above the safety height limit switch, the horn, the release solenoid valve and the lowering solenoid valve are operated and mechanical safeties are engaged.

EMERGENCY BUTTON (9)

- If it is pressed, the circuit will disconnect

TWO POSITION SELECTOR (11)

- In left position operates the lift.
- In right position operates the auxiliary lift (Models LT and LTAT).

For lifts equipped with play detector the selector has three positions :

- In left position operates the auxiliary lift (Models LT and LTAT).
- In middle positions operates the lift
- In right position operates the play detector.

1ST WORKING POSITION BUTTON (13)

- When pressed, the motor , the release hydraulic circuit solenoid valve and air solenoid valve are operated, and the lift can raise.

When the working position has been reached , the lift continue raising for a while, then it stops and lowering valve is activated.

When working position is reached the lift stops and after few seconds unlocking solenoid valve and lowering valve are activated to engage the mechanical safeties.

2ND WORKING POSITION BUTTON (14)

- The operation is the same as 1st working position button.



BE SURE THE SAFETY AREA IS FREE FROM PEOPLE AND OBJECTS

Lift operation can be summarized into four steps:

8.2 VEHICLE POSITIONING

- Stop slip plates by using the check pin (models “AT” and “LTAT”).
- Place the vehicle at the centre of the platform and check that it doesn't slide out.
- Check that all stopping devices are operating.

8.3 LIFTING

- Set the main switch (12) to position 1 and press the UP button (7) to lift the vehicle to the required level.

8.4 STANDING

- To let the lift stand, release the UP button and press the safety down button (5) till the required position is reached. This operation activates the beeper and a few seconds later, the lift goes in safety.

8.5 LOWERING

- Press the DOWN button (8) to carry out lowering .
The lift will raise for release the mechanical safety locks and then it will descend to a safety height of about *400 mm*.
Be sure the safety area is free of people and objects, then press the SAFETY DOWN button (5) that activate the beeper and a few seconds later, the final descent.



Warning : engage the mechanical safety locks when the vehicle is left on the runways for long periods (ex. during the night)

8.6 LIFT TABLE OPERATION

Turn the selector (11), on the front control desk, to utilize the lift table.

Adjust auxiliary lift platform extensions according to vehicle to lift

Place the rubber blocks under the picking point at the car

LIFTING

Press UP button (7) to lift vehicle to the required level

LOWERING

Press DOWN button (8), the lift will raise for a while to disengage the mechanical safeties. the lift stops at about 130 mm. Put extension inside the table, Then press the safety down button (5), that activates the beeper and a few seconds later, the final lowering.



before the lowering, make sure that the runways extensions are pushed back.

Damage caused to the lift, produced because of no observing the rules here indicated, absolve the manufacturer from liabilities.

8.7 MANUAL AND EMERGENCY LOWERING



Attention : this process requires that the mechanical security of the lift has to be disengaged during the lowering process.

If the mechanical safety locks are engaged, let them free as follows described:

- Disconnect the electric power before effect the movement;
- ensure personnel are not in the working area during the lowering steps of this procedure;
- unscrew the knurled nut (1) from the block of solenoid valve (2);
- remove the magnet (3) from solenoid valve (2);
- place the knurled nut (1) on solenoid valve (2) and tighten; with the hand pump, pump until the mechanical security locks are free;



Note : if the hand pump does not work, this must be bled as explained below.

Bleed the manual pump as follows described:

- release the screw (1) and remove it;
- fit the lever (2) pump until oil and air are coming out from the hole of the screw (1);
- insert again the screw (1) and tighten during pumping, until no air is apparent in the oil

Carry out the emergency lowering of main lift, after disengaging the mechanical safeties, as follows:

- place a suitable object between the mechanical security locks and the rack of the platform to ensure that the mechanical security locks remain disengaged during lowering;
- unscrew the knurled nut (5) of the platform lowering solenoid valve (6);
- remove the magnet (7) from solenoid valve (6);
- insert again the screw (5) up the solenoid valve (6) and slowly tighten to lower the platforms.
- the lowering speed increase by tightening the knurled nut (5).

Figure 37 –BLEEDING THE HAND PUMP

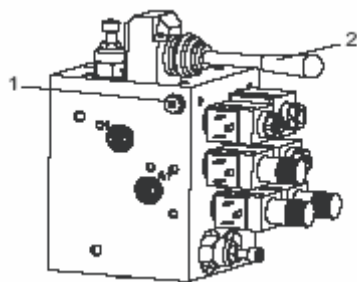

Modelli
“LT” e “LTAT”

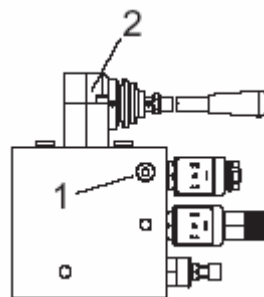

Modelli
“N” e “AT”

Figure 38 – LIFT EMERGENCY LOWERING - Models “N” and “AT”

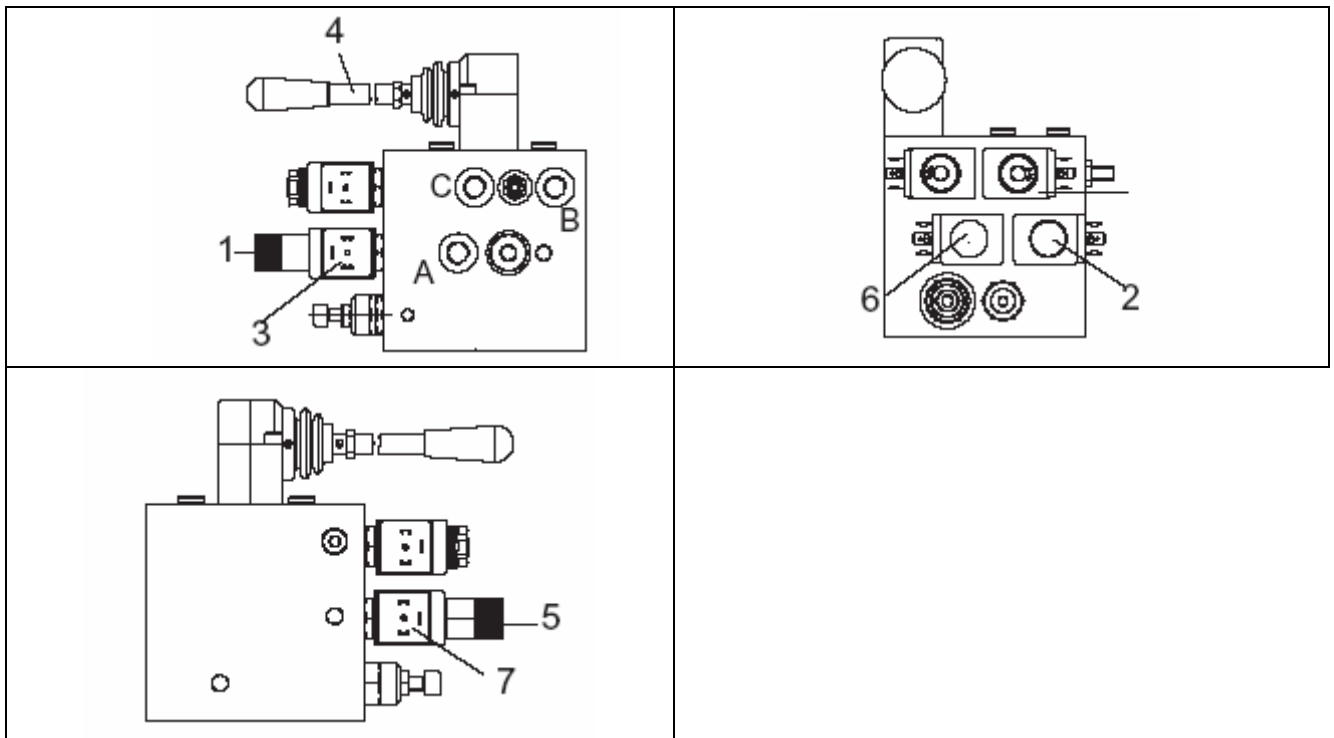
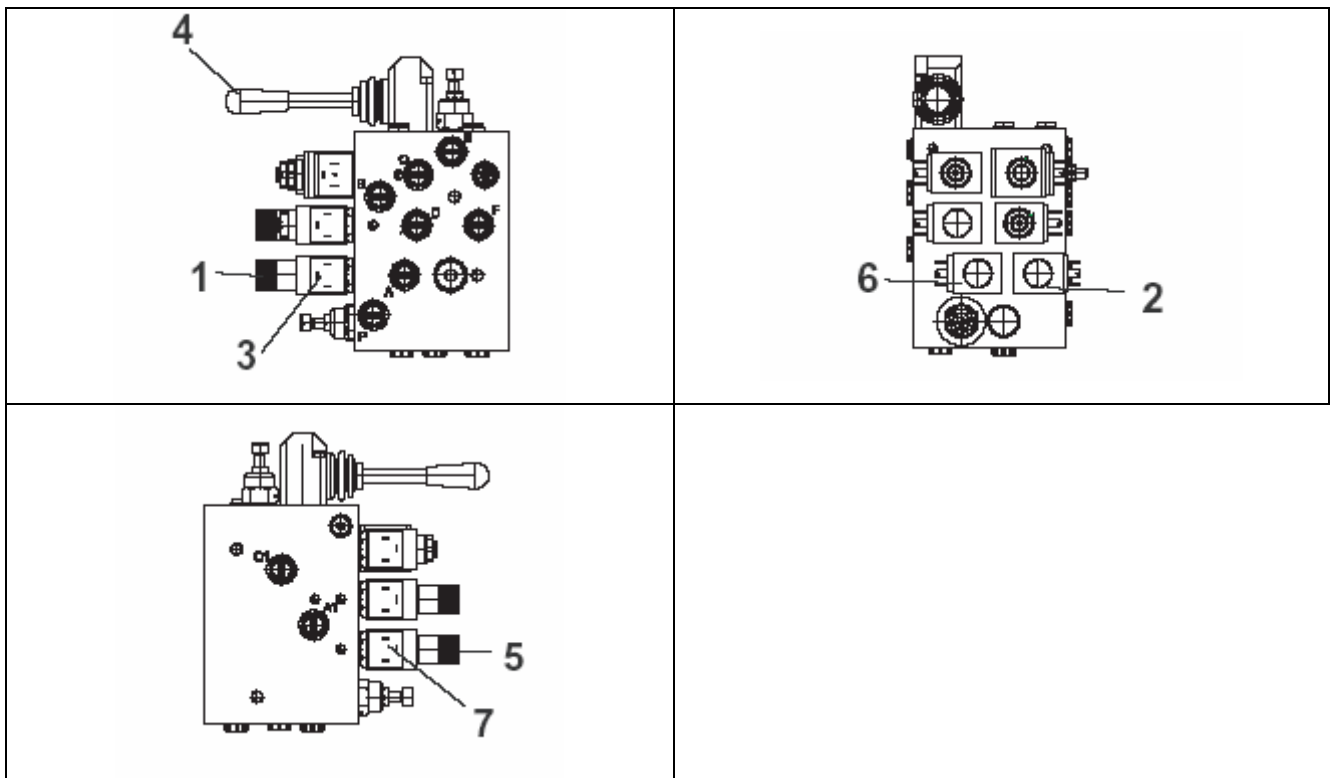



Figure 39 – LIFT EMERGENCY LOWERING - Modelli “LT” and “LTAT”



 **Attention : after manual lowering of the lift, reset original conditions and take care to not invert the two magnets.**

	The lift cannot be raised when the manual lowering valve is opened
--	---

8.8 AUXILIARY LIFT EMERGENCY LOWERING



Attention : if the main lift platforms and lift tables-are raised, the lift-tables must be lowered before lowering the main lift platforms.

MAKE SURE THAT THE RUNWAY EXTENSION OF THE LIFT-TABLES ARE REINSERT IN THEIR SEAT BEFORE PROCEEDING WITH THE FINAL LOWERING.

Carry out the emergency lowering of main lift, after disengaging the mechanical safeties, as follows:

- Disconnect the electric power before effect the movement;
- ensure personnel are not in the working area during the lowering steps of this procedure;
- unscrew the knurled nut (1) from the block of solenoid valve (2);
- remove the magnet (3) from solenoid valve (2);
- place the knurled nut (1) on solenoid valve (2) and tighten;
- with the hand pump, pump until the mechanical security locks are free;
- Loosen locking bolt of auxiliary lift manual lowering valve (5) (Rif.Figure 36 - mod. LT and LTAT) installed on the hydraulic block.
- Turn counter clock wise the dowel of the auxiliary lift manual lowering valve (5) to low the platforms together.

The lowering speed increases by opening the lift-table manual lowering valve (5).



Attention: in case of ranger during auxiliary lift lowering, it is possible to stop it by tightening the locking nut of manual lowering valve (5).



Attention : after manual lowering of the lift, reset original conditions and take care to not invert the two magnets.

The lift cannot be raised when the manual lowering valve is opened

Figure 40 – AUXILIARY LIFT EMERGENCY LOWERING

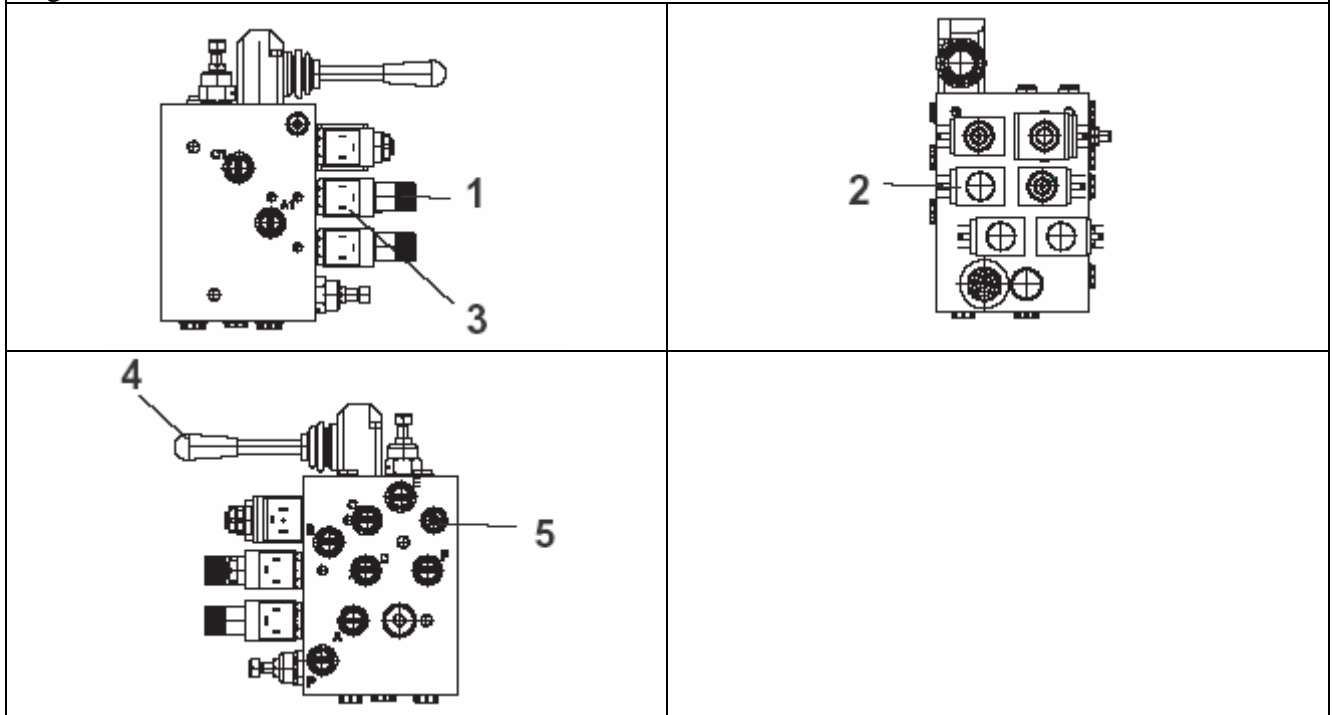

9 CHAPTER 9 - MAINTENANCE



ONLY TRAINED PERSONNEL WHO KNOWS HOW THE LIFT WORKS, MUST BE ALLOWED TO SERVICE THE LIFT .

To service the lift, the properly following has to be carried out:

- use only genuine spare parts as well as equipment suitable for the work required
- follow the scheduled maintenance and check periods shown in the manual
- discover the reason for possible failures such as too much noise, overheating, oil blow-by, etc.

Refer to documents supplied by the dealer to carry out maintenance:

- Refer to functional drawing of the electric and hydraulic equipment
- Refer to exploded views with all data necessary for spare parts ordering
- Refer to list of possible faults and relevant solutions..



Before carrying out any maintenance or repair on the lift, disconnect the power supply, padlock the general power supply switch and keep the key in a safe place to prevent unauthorized persons from switching on or operating the lift

9.1 ORDINARY MAINTENANCE

The lift has to be properly cleaned at least once a month. Use a self-cleaning cloth.



THE USE OF WATER OR FLAMMABLE LIQUID IS STRICTLY FORBIDDEN

Be sure the rod of the hydraulic cylinders is always clean and not damaged since this may result in leakage from seals and, as a consequence, possible malfunctions.

9.2 PERIODIC MAINTENANCE

Every 3 months	Hydraulic circuit	<ul style="list-style-type: none"> ▪ check oil tank level; refill with oil, if needed; ▪ check the circuit for oil leakage. ▪ Check seals for proper conditions and replace them, if necessary;
	Foundation bolts	<ul style="list-style-type: none"> ▪ check bolts for proper tightening
	Hydraulic pump	<ul style="list-style-type: none"> ▪ verify that no noise changes take place in the pump of the control desk when running and check fixing bolts for proper tightening
	Safety system	<ul style="list-style-type: none"> ▪ check safety devices for proper operation
Every 6 months	Oil	<ul style="list-style-type: none"> ▪ Check oil for contamination or ageing. Contaminated oil is the main reason for failure of valves and shorter life of gears and pump
Ogni 12 mesi	Controllo generale	<ul style="list-style-type: none"> ▪ verify that all components and mechanisms are not damaged
	Impianto elettrico	<ul style="list-style-type: none"> ▪ a check of the electrical system to verify that control desk motor, limit switches and control

		panel operate properly must be carried out by a skilled electrician
--	--	---

10 CHAPTER 10 - TROUBLESHOOTING

A list of possible troubles and signaling failures, and solutions is given below.

Trouble:	Possible Cause:	Solution:
The lift does not work	<p>The main switch is not turned on There is no power The electrical wires are disconnected Fuses are blown The emergency button is pressed</p>	<p>Turn the switch on Check power and restore if necessary Replace Replace Restore the button properly</p>
The lift does not raise when the UP button is pressed (the pilot lam is ON)	<p>The motor direction of rotation is not correct. The oil in the hydraulic unit is not sufficient.</p> <p>The UP button is faulty.</p> <p>The maximum height limit switch sensor is faulty.</p> <p>The lowering valve does not close. The suction pump filter is dirty.</p> <p>The emergency button is pressed in The safety height limit switch is not correctly adjust or it is defective as consequence the photocell does not read The photocell sees an obstacle as a consequence does not read The reflector is defective as consequence the photocell does not read The platforms aren't leveled and as consequence photocell does not read The photocell isn't correctly positioned as consequence does not read</p>	<p>Interchange the two phases on the main switch Add some hydraulic oil. Check UP button and connection for proper operation. Replace, if needed</p> <p>Check the max. height and relevant connection for proper operation. Replace, if needed. Check and clean, if dirty, or replace, if faulty Check and clean if needed.</p> <p>Restore the push button properly Adjust or change the limit switch</p> <p>Remove the obstacle</p> <p>Replace the reflector</p> <p>Check hydraulic circuit and leveling devices</p> <p>Restore the correctly position</p>
The lift does not lower when the DOWN button is pressed (the pilot lamp is ON)	<p>The motor does not operate properly and does not release the mechanical safeties</p> <p>The lift raises to disengage the mechanical safeties and does not lower : Because air solenoid valve does not work properly Because the air does not reach the circuit Because electric board is faulty</p> <p>The lowering solenoid valve does not discharge</p> <p>The release solenoid valve is not operating</p> <p>The DOWN button is faulty</p> <p>The safety height limit switch is not correctly adjusted or it is defective as consequence photocell does not read The photocell sees an obstacle as a consequence does not read The reflector is defective as consequence the photocell does not read The platforms aren't leveled and as consequence photocell does not read The photocell isn't correctly positioned as consequence does not read</p>	<p>Check the motor</p> <p>Replace air solenoid valve</p> <p>Check compressor and air pipe Replace electric board Verify if it is powered and check the magneto for damages (replace if disconnected or burnt) Verify if it is powered and check the magneto for damages (replace if disconnected or burnt) Check the DOWN button and connection for proper operation. Replace, if needed</p> <p>Adjust or change the limit switch</p> <p>Remove the obstacle</p> <p>Replace the reflector</p> <p>Check hydraulic circuit and leveling devices</p> <p>Restore the correctly position</p>

The lift does not stop at the safety height (400 mm)	The safety height limit switch is not adjusted correctly or it is faulty The electric board is faulty	Adjust or change the limit switch Replace electric board
The lift-table does not raise when push UP button (with selector qualified)	The selector is faulty (if the lift goes up instead of the lift-table) The electric board relay K1 is faulty (if the lift goes up instead of the lift-table) The lift-table height switch is not adjusted correctly or is faulty The cylinders solenoid valve block are dirty, defective or they are not powered The electric board is not operating	Replace the selector Replace the relay or electric board Adjust or change the limit switch Clean, if necessary replace or verify if powered and check magneto for damage Replace the electric board
The lift-table does not make auto-leveling	The auto-leveling limit switch is not adjusted correctly or is faulty The auto-leveling solenoid valve is dirty, faulty or is not powered The electric board K4 relay is faulty	Adjust or change the limit switch Clean, if necessary replace or verify if powered and check magneto for damage Replace the relay or electric board
The lift-table does not lower when DOWN button is pressed (with selector qualified)	The lift-table safety height limit switch is not adjusted correctly or is faulty The lift-table lowering solenoid valve is dirty, faulty or is not powered The electric board is not operating The motor does not work and does not disengage the mechanical safeties Down button is faulty	Adjust or change the limit switch Clean, if necessary replace or verify if powered and check magneto for damage Check the fuses and replace the electric board if necessary Check the motor Check the DOWN button and connection for proper operation. Replace, if needed
The lift-table doesn't lower in a correct way (present tugs)	Presence of air in hydraulic circuit	Bleed the hydraulic circuit
The lift isn't raising synchronous.	Presence of air or dripping in the hydraulic circuit. The lift-table lowering solenoid valve is faulty The cylinder gaskets can be damaged	Bleed the hydraulic circuit. Replace the solenoid valve Check and replace if necessary
The lifting capacity is limited	The oil in the tank is not enough The pump is faulty Safety valve is not settled properly	Fill oil in the tank Check the pump and replace if necessary. Adjust the valve setting
The platform P2 doesn't lower correctly	The P2 auto-leveling limit switch is faulty The P1 auto-leveling limit switch is faulty Leveling solenoid valve does not operate	Replace the limit switch Replace the limit switch Clean the valve or replace it if necessary

CHAPTER 11 – EC DECLARATION OF CONFORMITY

In the meaning of the EEC Machinery Directive
98/37 EC, Annex II A for installed machines.

BlitzRotary GmbH
Hüfinger Straße 55
78199 Bräunlingen

Germany

Declares on one's own responsibility that the equipment specified below:

Type of equipment: Scissor Lift

Model: M50

To which this declaration is related, conforms with the following European directives:
98/37/CEE - 73/23CEE- 93/68 CEE - 89/336

It also declares that the following European rules have been respected :

EN 292.1- EN 292.2- EN294-EN 349- EN 1050- EN 60204-1. ETS 300 683 EN 55022B – EN1493.

Bräunlingen, 10/08/2006

A handwritten signature in black ink, consisting of a stylized 'L' followed by a cursive 'R'.

(Signature or stamp of the authorized person)

Trained Operators and Regular Maintenance Ensures
Satisfactory Performance of Your Rotary Lift.

Replacement Parts: See installers package for parts breakdown sheet.
Order Genuine Rotary replacement parts from your nearest Authorized Parts Distributor.

Maintenance Assistance: Contact your local Rotary distributor.

Should further assistance be required, contact Rotary Lift, at one of the phone numbers listed below.

World Headquarters:
Rotary Lift
A **DOVER** COMPANY
2700 Lanier Drive
Madison, Indiana USA
Phone: 1.800.445.5438
Phone: 1.812.273.1622
Fax: 1.800.578.5438
Fax: 1.812.273.6502
userlink@rotarylif.com
www.rotarylif.com

Germany:
(European Headquarters)
BlitzRotary GmbH
Bräunlingen
Phone: +49.0771.9233.0
Fax: +49.0771.9233.99
europe@rotarylif.com

Canada:
(Regional Sales Office)
Rotary Lift Canada
Mississauga, Ontario
Phone: 888.256.4195
Phone: 905.812.9920
Fax: 905.812.9719
canada@rotarylif.com

United Kingdom:
(Regional Sales Office)
Rotary Lift (UK) LTD.
Halstead, Essex
Phone: +44.178.747.7711
Fax: +44.178.747.7720
sales@rotarylif.idps.co.uk

Austral-Asia:
(Regional Sales Office)
Rotary Lift Austral/Asia
Petaling Jaya, Malaysia
Phone: +60.3.7660.0285
Fax: +60.3.7660.0289
rlim@rotarylif.com

